

Pellet Condensing Boiler
ETA ePE BW 8-22 kW



... my heating system



**State-of-the-art condensing technology
for new builds and renovations**



A passion for perfection.

www.eta.co.at

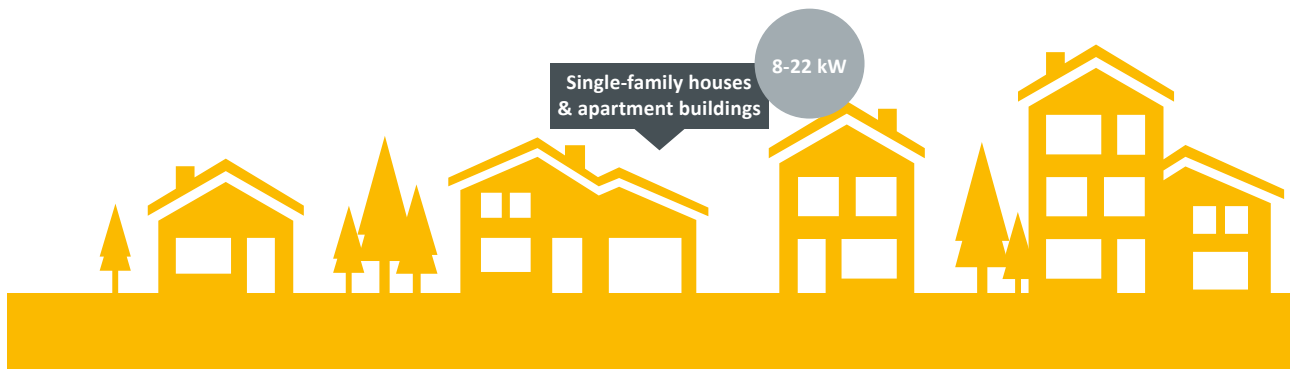

No one is smaller

With a footprint of less than 0.5 m², the ETA **ePE BW** is the smallest high-tech pellet boiler with condensing technology, integrated hydraulics and precipitator on the market. And because the connections are flexible, it can be installed almost anywhere.

The ETA **ePE BW** is the ideal pellet boiler for refurbishment when using underfloor or wall heating or for new constructions of single family housing and apartment buildings. The entire heating system is packed into a compact boiler. High efficiency pump, safety devices and more are already integrated. This not only reduces the space needed, but also the assembly costs. And the operating costs drop too. This is ensured by state-of-the-art boiler technology and, in this model, also by the integrated condensing heat exchanger. It also uses the waste heat for heating and thus further increases efficiency. And the ETA **ePE BW** is also flexible: even a second heating circuit can be integrated!

Can be set-up anywhere

If necessary, the ETA **ePE BW** extracts the oxygen required for combustion from the outside. Thanks to this operation with external air supply, the boiler may be placed not only in ventilated boiler rooms, but also in heated buildings or in rooms with comfort ventilation. Placement in the living room is also no problem visually: the ETA **ePE BW** looks so good that people like to show it off.

Wooden briquettes for maximum comfort

Pellets are balls of energy made from compressed wood by-products. Those who use the small and powerful briquettes heat fully automatically and at the highest level of convenience. Only the ash bin needs to be emptied every now and again. The pellet store room can be up to 20 metres away from the heating boiler and needs no more space than the room of an oil tank. The ETA **ePE BW** is also ideal for all heating refurbishers who want to protect the climate and reduce operating costs.

A win-win situation

Save heating costs, boost your domestic economy and look after the environment in the process: heating with pellets is worth it. Currently, around 7 million cubic metres of excess wood is growing in Austria - and forested areas are increasing across the whole of Europe.

Using resources sensibly

In contrast to fuels such as oil and gas, pellets hardly effect the climate. That is because trees absorb as much CO₂ during growth as they later release during combustion. In addition, the CO₂ released during combustion is equal to or less than that of naturally rotting wood.

Wood cutting in the sawmill

100 % Softwood* (without bark) surrendered:

Lumber (60 %)

Sawing by-products (40 %)

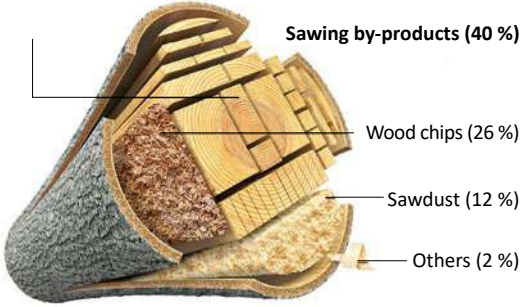

Wood chips (26 %)

Sawdust (12 %)

Others (2 %)

*More than 95 % of the cutting in German sawmills is based on softwood

Source: Döring, P.; Mantau, U: Locations of the wood industry - cutting and sawing by-products 2010. Hamburg, 2012. Conversion: DEPI. German Pellets Institute, using images from mipan / 123RF.com and Can Stock Photo / dusan694

No extra trees have to be felled to produce pellets, because the powerful briquettes consist mainly of sawdust, a waste product of the wood industry.

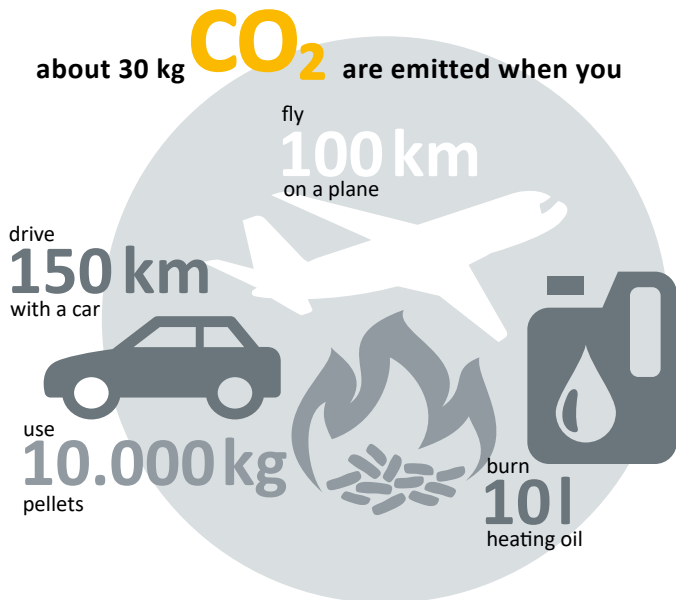

Oil in comparison

Calculation time period: 5 years

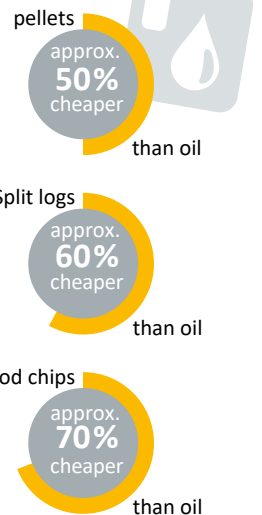

Fuel costs: oil and pellets in comparison

2 tonnes of pellets roughly correspond to 1,000 l of heating oil

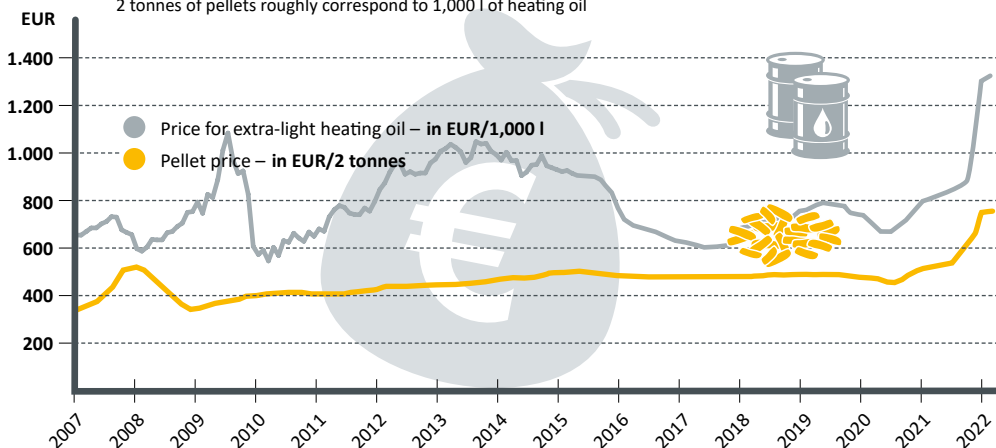

Always space for pellets

The pellet store can easily be set up anywhere an oil tank has previously stood. It doesn't even have to be near the boiler, but can be located up to 20 m away. If the pellet store is located beneath the boiler, and if using a suitable conveying system, up to two storeys can be overcome. If there's no space in the house, the store room can also be set up in an adjacent building or an underground tank can be used. The store room just needs to be dry so that the pellets don't swell up. Wooden cladding can help in rather damp rooms.

A clean solution

The pellets, which are created from the compacted waste products of the wood industry, are delivered by tanker lorry and blown into the store room. So the delivery of pellets is an extremely clean and easy process. If the store is sealed, no dust can escape here either.

Attractive also for complete renovations and new builds: with a well insulated house, 6 m² is often sufficient for the heating and pellet storage room.



How big does my store room have to be?

The approximate pellet requirement per year in tonnes is calculated by dividing the heating load in kilowatts by 3. To calculate the pellet requirement in cubic metres, divide the heating load by 2. So, for example, for 30 kW heating load you need approx. 15 m³ or 10 tonnes pellets per year. When moving from another energy source, the pellet requirement can also be determined from the previous consumption.

1 ton of pellets roughly corresponds to:

- 500 l heating oil
- 520 m³ natural gas
- 750 l liquid gas
- 600 kg coke (fuel)
- 1,400 kWh power with geothermal energy pumps (coefficient of performance 3.4)
- 2,700 kWh power with air heat pumps (coefficient of performance 1.8)

How do the pellets get to the boiler?

Discharge screw: It stretches the entire length of the store room, can be up to 6 m long and transports the pellets from the store room to the transport hoses, which lead to the boiler. From here, the pellets are conveyed further. After transport the hoses are vacuumed empty. Hence they do not clog up and always work with the highest degree of efficiency. With this standard system, the store room can be completely emptied.

Over the inclined smooth floor, the pellets automatically slide to the transport screw. The impact protection mat is suspended opposite the filling nozzles, so that the pellets do not shatter on the wall when they are blown into the store room from the truck. The prerequisite for this construction is that the connections for the transport hoses to the boiler are located on the narrow side of the store room, so that the whole length of the room can be used with the screw.

Back air and filling nozzles

Impact protection mat

Return and suction hose

With the ETA System, pellet transport goes particularly quickly - the suction times are very short.

Pellets conveying system „FLEX“

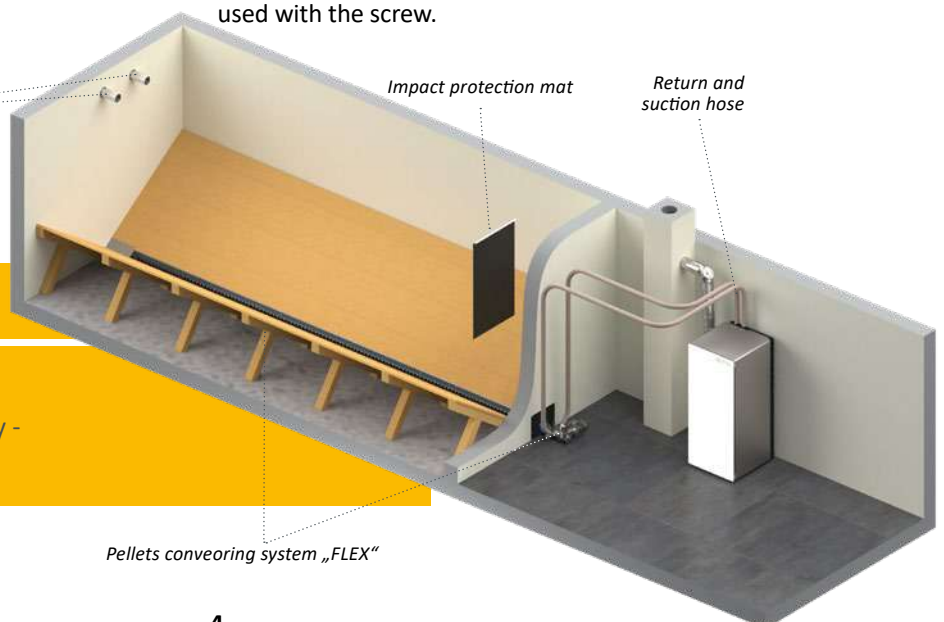

Suction probes:

If the shape of the room is not suitable for a discharge screw, the ETA switching unit system is the ideal choice. Here, the pellets slide over the slanting and smooth wooden floor directly to the four suction probes, which alternately transport pellets away from the store room. Through automatic changeover, the fuel supply is not interrupted if a probe doesn't get any pellets at a certain

point in time. The prerequisite for this system is that the store room is situated opposite the boiler in the same storey or higher, and that the store room is no longer than 4 m. Unlike screws, the suction probes do not fully empty the store room. When the storage room capacity is tight, this can be a disadvantage. The advantage is that this system can be used even in angled store rooms.

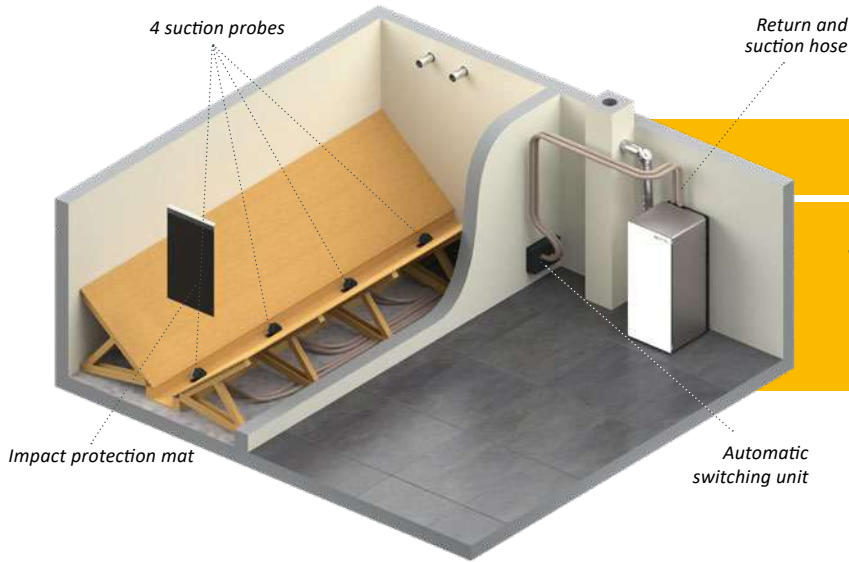

With the suction probes, nearly any room can be used as a pellet store, even if the store room is angular.

Mole conveying system:

Due to the structural constraints, conventional ETA pellet conveying systems may have some limitations in terms of usable pellet storage volume. The high quality E3 mole conveying system is a useful application in this situation.

ETA tip: storage in the ETA Box

One particularly practical solution is the ETAbox. It can be set up in the boiler room, in an attic, in a barn or – if covered – even outside. It even keeps the pellets dry in damp rooms. Distances of up to 20 metres of suction hose stretching from the box to the boiler are no problem. Please note that the ETAbox cannot be set up directly on a wall. This is why the space required is a bit larger compared to a brick store with the same capacity.

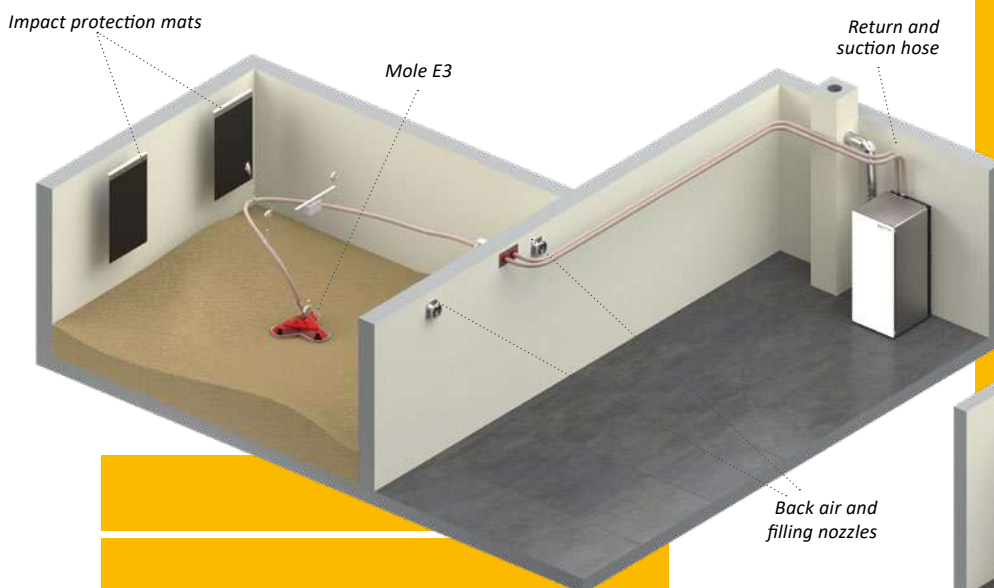

With the E3 mole conveying system, the storage space can be almost completely emptied and the sloping wooden structure is eliminated.



Heat, just the way you need it

The ETA ePE BW doesn't just produce heat, the ETA System also distributes it efficiently. Rely on the perfect control centre for your heating and hot water system.

The ETA ePE BW is equipped with a control system for the entire heating system. Whether you want to integrate a solar heating system, a conventional domestic hot water preparation system or a buffer storage tank with fresh water module, whether the energy is transferred with radiators or via floor or wall heating: everything is controlled from a touchscreen on the boiler or via a computer or smartphone. Simple images show you if your solar heating system was operating or how full your buffer is.

With buffer, please

Of course the ETA ePE BW can work by itself. However the ETA buffer storage tank is its perfect partner. Above all, when heating in autumn or in spring and for hot water preparation in the summer, often less energy is needed than the boiler

No matter whether you want to integrate a solar heating system, a domestic hot water preparation system or a buffer storage tank with a fresh water module: the whole system can easily be controlled from a touch screen on the boiler.

Remote controlled via the meinETA communication platform



produces. The buffer stores this excess heat and releases it on demand. This saves fuel and protects the boiler, because fewer boiler starts are needed.

The ETA stratified buffer is ideal for the integration of a solar heating system. In summer, hot water can be produced at virtually no operating costs. But in winter, the solar collectors seldom produce the 60 °C that are common for domestic hot water preparation. Then the water that is heated by solar energy is fed through the underfloor or wall heating. This usually works with hot water temperatures of just 30 to 40 °C.





Everything at a glance!
The ETA room sensor displays the room temperature and the outside temperature and enables a simple change of the desired room temperature.

ETA individual room temperature control. A pleasant temperature, one room at a time

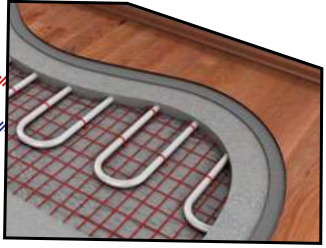

Direkter Anschluss eines Heizkreises aus dem Kessel ohne externe Pumpen im Heizraum.

The ETA stratified buffer can also be equipped with a fresh water module, which constantly reheats the tap water with the help of a heat exchanger. This ensures that the risk of germs and bacteria is minimised.

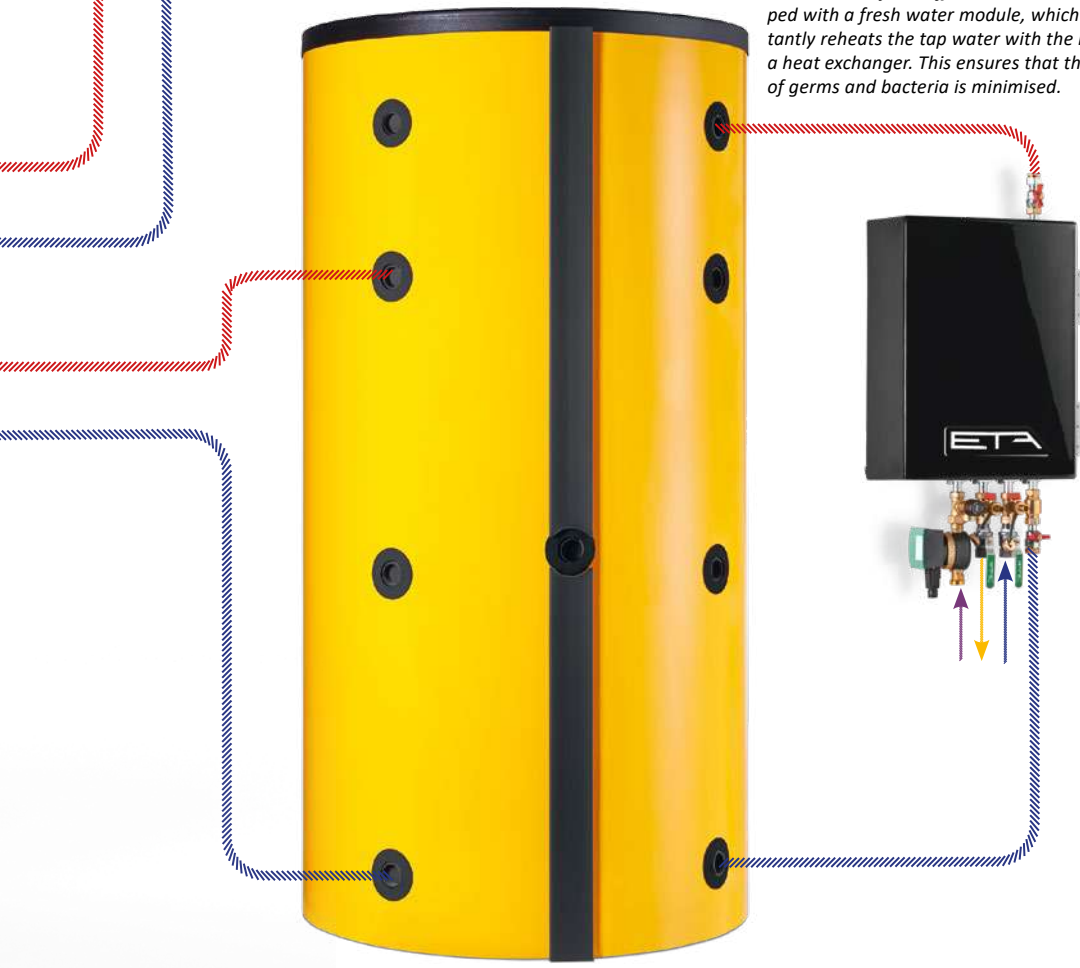

An ETA stratified buffer is the ideal addition to a ePE BW. It stores energy that is not required and delivers it on demand.



Safe, reliable and easy to use

When selecting a new boiler, you are making a decision that can have an effect on your daily life for many years. You determine how relaxed you feel and how much you have to worry about maintenance and cleaning. This is where quality at a fair price pays!

Automatically clean

The ETA ePE BW cleans itself automatically – and not just at certain intervals, but precisely when it's needed. This ensures low emission values and the highest degree of efficiency during the heating season. You never have to open the combustion chamber and get yourself dirty. Not only is the combustion chamber de-ashed effectively, the heat exchanger is also regularly cleared of deposits. As the pellets are burnt very efficiently, less ash is produced. In addition, the ash is compacted in the ash box. Which is why it only needs to be emptied occasionally. And this is easily and quickly done.

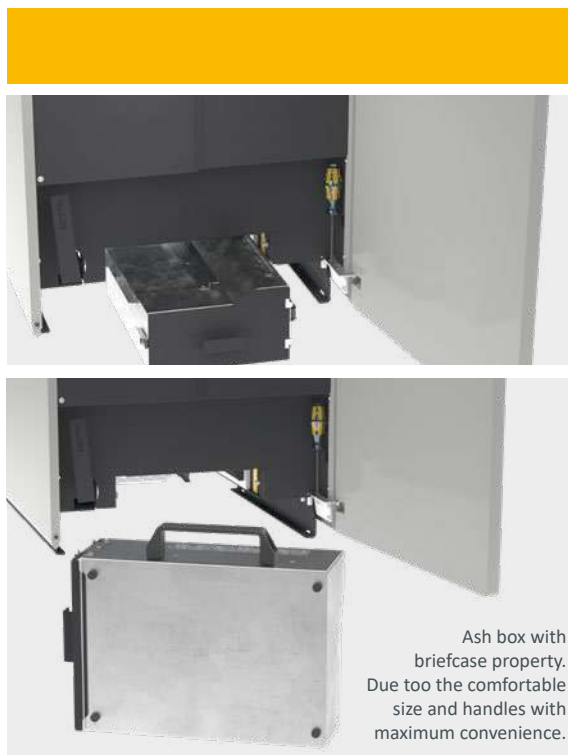

Ash box with briefcase property. Due too the comfortable size and handles with maximum convenience.

Rotary valve

The safe system. The rotary valve completely protects you from burn-back: burning should only take place in the combustion chamber and nowhere else.

A transport screw brings the pellets to the rotary valve – and only as many as the rotary valve can handle. This is why the pellets do not become wedged, crushed or broken. Thanks to this ETA developed system, the sealed edges of the rotary valve do not wear out. The system remains safe throughout the entire life of the boiler.

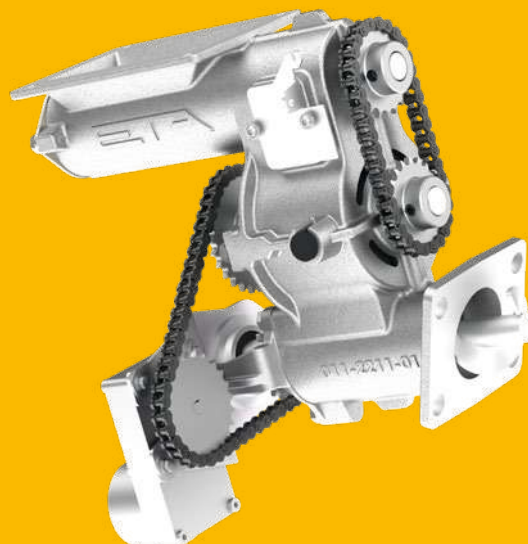



Rear view of the boiler
You can find more information in
the technical data on page 18

Flexible connection options

Quickly set up anywhere.

Thanks to the flexible connections for hydraulics, flue pipe, supply air and condensate, you can install the ETA ePE BW not only on the wall, but also in a corner. During installation, the hydraulic connections can easily be turned to the left or right in the desired direction, the condensate drain can be located on the right, left or rear, and the supply air and flue gas connections are optionally on the left or rear.

Operation with external air supply.

The ETA ePE BW can take the oxygen required for combustion from outside instead of from the ambient air inside. This means the boiler can also be located within a heated building shell, without having to permanently open a window in the deepest of winter.

Noiseless ceramic igniter

Sparking technology. The energy used for ignition is much lower than other ignition systems. The ignition itself works quicker.

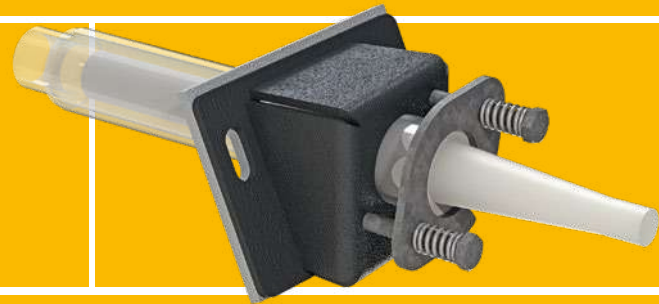

Lambda probe

It's about the mix. With its help, the ratio of fuel and oxygen are mixed perfectly. This means that different pellet qualities achieve the best possible efficiency. In addition, the probe immediately detects if the ignition was successful. This reduces the ignition time and saves power and money.

Control system

Versatile, but not complicated.

Whether combustion control, pellet conveying, buffer management, domestic hot water preparation, weather-compensated heating circuit controlled with a weekly program for two circuits or the connected solar heating system: all of this can be controlled via a touchscreen directly on the boiler or via the internet from any PC, smartphone or tablet. It is a lot, but it is easy to handle as the images on the touchscreen are self-explanatory.



The way to heat

From pellet hopper to combustion chamber to pump: the interplay of high-quality components is needed!



- 1 Aspirator:** It transports the pellets from the store room to the boiler's intermediate hopper.
- 2 Pellet intermediate hopper:** Here 30 kg of pellets are stored temporarily and are immediately available for use. This means pellets have to be transported from the store room to the boiler only once or twice a day for approx. 5 minutes. You can even control when that is.
- 3 Rotary valve as burn-back protection:** It is the completely sealed closing door between store and combustion chamber and therefore safely protects against burn-back.
- 4 Automatic de-ashing in the ash box:** The small amount of ash that still falls despite the optimised combustion processes is firmly compacted in the ash bin. The ash bin only needs to be emptied every now and again. When it's time, the boiler sends a reminder by email.
- 5 Draught fan:** Quiet as a whisper, this fan ensures underpressure in the boiler. Additionally, it controls the air quantity and thus ensures safety in the boiler room.



Boiler section from the left



The way through the boiler:

-  Fuel
-  Flue gases
-  Heating water

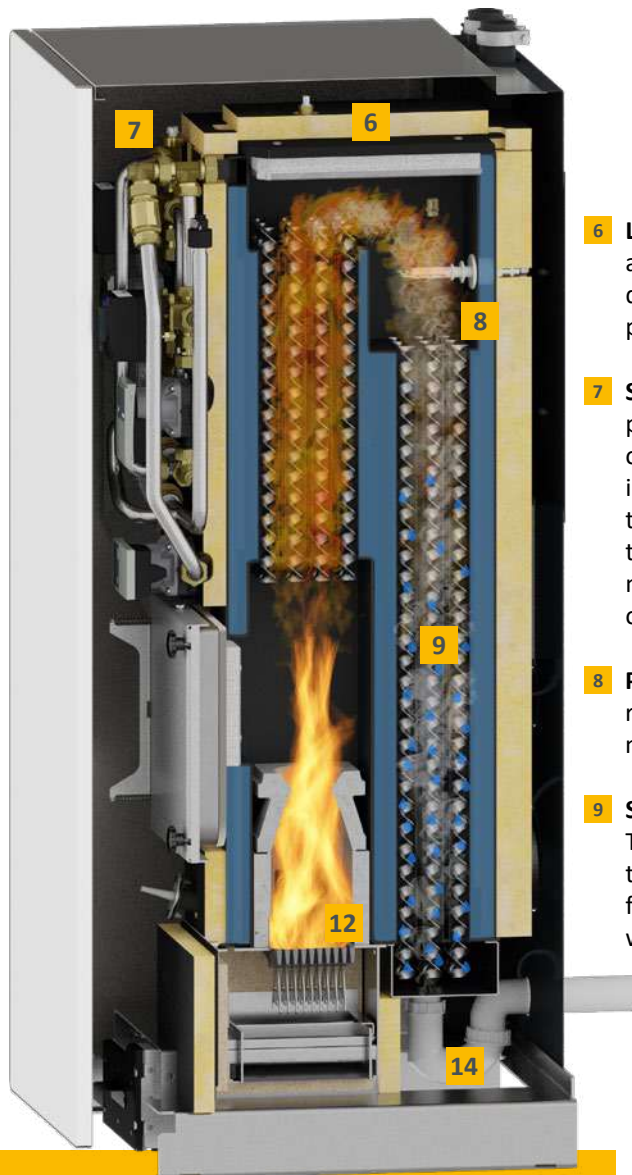

- 6 Lambda probe:** With its help, the ratio of fuel and oxygen are mixed perfectly. This means that different pellet qualities always achieve the best possible efficiency.
- 7 Safety devices:** A safety valve and an electronic pressure sensor protect the boiler from overpressure. An automatic bleed valve is also integrated, so unwanted air is removed from the water circuit. The boiler does not need a thermal emergency cooling valve, as there is never too much fuel in the boiler that could cause overheating.
- 8 Precipitator:** The optional integrated precipitator reduces the dust load in the flue gas to a minimum. The environment loves it!
- 9 Stainless steel condensing heat exchanger:** To prevent valuable energy from being wasted through the chimney, it extracts the residual heat from the flue gas and adds it back to the boiler water.



Boiler section from the right

- 10 Mixer:** It can be flexibly used depending on system type. With a pluggable actuator, it functions as a flow mixing valve for a heating circuit or as a return riser with mixer for buffer storage tank operation.
- 11 Pump:** It is speed-controlled, highly efficient, energy-saving and ensures the optimum movement of hot water. Depending on the system type, it is either the heating circuit pump for an underfloor heater or radiator heating or it handles buffer charging.
- 12 Combustion chamber:** Here, temperatures are produced that are high enough to burn wood cleanly and efficiently. This ensures less ash and low emissions, even under partial load.
- 13 Heating circuit:** The optional integrated heating circuit is installed in the boiler to save space. This means that no mixer or pump has to be installed externally in the boiler room for this heating circuit.
- 14 Condensate drain:** The condensate produced in the condensing heat exchanger is discharged into the waste water system via a siphon.

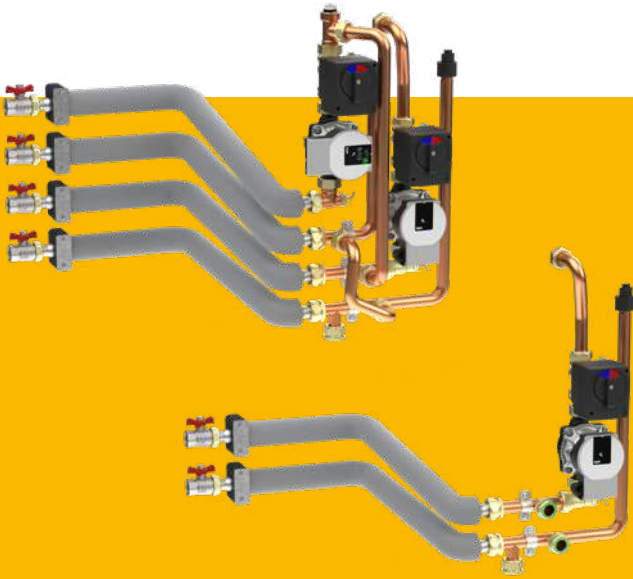

Everything already in it

The most important elements for the heat distribution such as the pump, mixer and changeover valve are also integrated into the boiler like the safety valve, manometer and bleed valve.

Optionally, the installation of a mixing circuit for buffer operation or an additional heating circuit for operation without buffer tank is possible. That saves space and make the installation easier.

Draught fan

Negative pressure in the boiler. Quiet as a whisper, this speed-controlled fan ensures negative pressure in the boiler and determines the air quantity for the combustion. Energy-saving it ensures consistent combustion results – largely independent of the condition of the chimney.

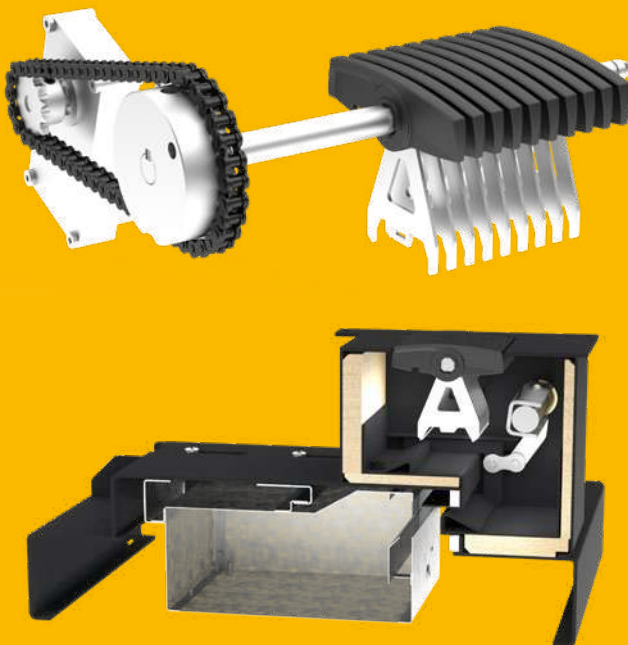

Revolving grate with cleaning comb

Clean burns well. This patented system cleans the combustion chamber of ash regularly – automatically after pellets are burnt. The air required for the combustion process is distributed evenly between the clean grate segments. Additionally, the grate is constantly kept in slight motion. The gentle movement stokes the firebed and thus ensures even better combustion.

The ash is compacted and ends up in the 12 l capacity ash box. Even at full load operation, it only has to be emptied from time to time. When it is needed, the system sends an email or an SMS message. The information is also displayed on the touch display.



ETA BW condensing heat exchanger

The ETA ePE BW even makes optimum use of the flue gas. Depending on the heating water temperature required, the integrated stainless steel condensing heat exchanger saves up to 10% fuel by extracting energy from the flue gases before they are discharged through the chimney. The flue gas is cooled below the dew point and the released heat is fed into the heating water. The best effect is achieved in combination with a panel heating system or when using a fresh water module for hot water preparation, i.e. whenever the return temperatures are low.

Automatic dedusting

The system cleans itself, partly simply with the condensation water. If necessary, it is additionally flushed. A volume flow sensor determines the amount of water and thus ensures the lowest possible water consumption based on demand.



Precipitator

Clever use of a natural phenomenon

Why does dust keep building up on the computer screen? It is because the dust particles are electrostatically charged and are attracted by the screen. – ETA makes use of this effect in its precipitator. With the aid of an electrode in the flue gas duct the particles which are swirling in the flue gas are energised and ionised. They are deposited on the internal wall of the separator and can no longer escape from the chimney with the flue gases.



The optional precipitator makes heating with wood even cleaner and more environmentally friendly. It extracts the dust from the flue gases by means of electric current.



Away mode, set-back mode, vacation setting: intuitively, you know immediately which button does what.

Easy to control from anywhere

Good technology is characterised by its user friendliness. You don't have to be a technician to use the many functions of the ETAtouch.

ETAtouch: the touchscreen on the boiler

Confusingly arranged buttons and control systems are a thing of the past, because with the touchscreen of the ETA PelletsUnit you can quickly and easily control every setting. The icons are self-explanatory. Whether you generally want to make it warmer or cooler, change the time for set-back mode or want to switch to eco mode during your vacation - you will tap on the right symbol intuitively and entirely without reading operating manuals!

You not only control your boiler via the touchscreen, but also have an overview of all connected components, such as buffer storage tank, pellet store, solar heating system or domestic hot water preparation. You know straightaway, for example, how many pellets you still have in store or how effective your solar heating system was.

meinETA: the free internet platform

If your boiler is connected to the internet, you can see and change all heating settings on your mobile, tablet or PC. So you always have a handle on your heating, wherever you are! When you login to www.meinETA.at, you see the touchscreen as if you were standing right in front of the boiler! The pellet store needs filling, the ash bin must be emptied, it's time for the next heating service... You don't have to remember all these things yourself. meinETA reminds you for free by email.

You can control the boiler via smartphone, PC or tablet as well as directly on the touchscreen.



Quick help

Give your installer or the ETA customer service representative temporary access rights to your meinETA account. So they can prepare for their visit to you. And maybe the technician doesn't even have to visit, because thanks to meinETA they can tell you over the phone what you need to do to make your boiler work again. You can see who can access your boiler via the status display. Only you decide who's in your partner network!

For tablet, smartphone and PC

meinETA runs on all current operating systems, such as iOS or Android. Via PC, meinETA can be loaded by any modern internet browser, such as Mozilla Firefox, Safari, Google Chrome or Internet Explorer 9.



Technical requirements for meinETA

In order to use meinETA, you need a broadband internet connection in the house.

The boiler's touchscreen is connected to the Internet via a network cable.

If you don't have a network connection in the basement, simply connect via the ETA PowerLine. It conveniently transmits the data to the modem via any socket.

As convenient as an app -
for free and with
full functionality on
the heating system!

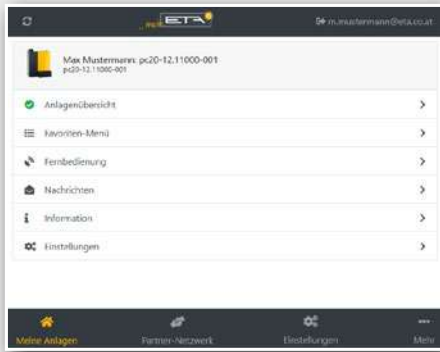

User interface of the meinETA platform



It's all very simple

mein ETA system 2.0 is now even more convenient to use. Simply register once, as with an app, and use all functions without restrictions and free of charge.

LOXONE



KNX Interface



Perfect for your smart home

The ETAtouch control system can be easily integrated into standard smart home systems and into a building management system (BMS). The miniserver of the LoXone system exchanges data directly with the boiler via a ModbusTCP interface. Even when connecting to a KNX bus system, all it takes is the optionally available ETA KNX interface and a few simple clicks.

ETA individual room temperature control interface example

Whether LoXone, KNX or ETA individual room sensor with or without display: everything can be controlled via ETAtouch. It always sends the correct signals to the valve controllers, which control how much hot water should get through to the respective room or heating section.

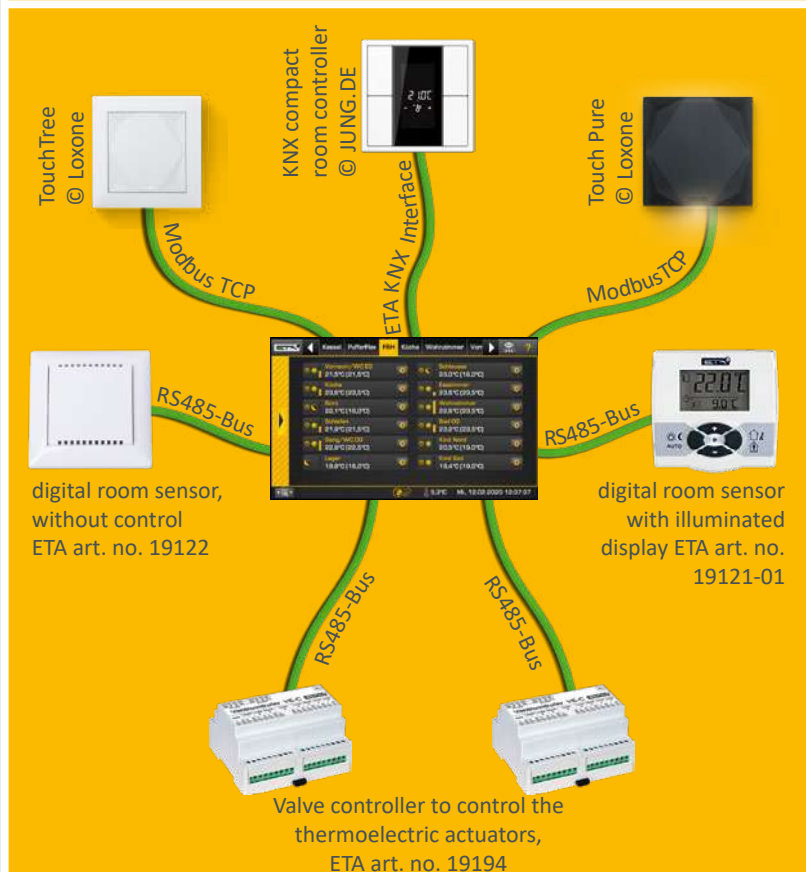

Everything on one display: the ETA Standard

A modern heating system is only effective if it is well-controlled. ETAtouch takes care of that.

At no added cost, the ETAtouch control system already includes all functions for two heating circuits, hot water supply via tank or instantaneous hot water module, as well as for the integration of a solar heating system. All ETA heating boilers also come with a LAN connection as standard. If you connect the boiler to the internet, you can easily control all components from a PC, tablet or smartphone.

Boiler and combustion regulation*

Speed-controlling the several components save power. The lambda and ignition time regulation increases efficiency. All components relevant to operation are monitored.

Buffer storage tank management**

Three to nine sensors in the tank control the heat generator in the system and distribute the energy to the different consumers. From using five sensors, cascading regulation, QM-Holz and peak load management are part of the ETA Standard.

Domestic hot water preparation*

Is made possible both via the ETA instantaneous hot water module but also via the hot water tank or combination tank. For all variants, circulation pumps can be controlled with time and/or requirement programs.

Solar heating systems**

Single or double circuit solar heating systems with one or two tanks, zone loading via the ETA stratified charging module and also two collector fields as well as three consumers are controlled.

Two weather-controlled mixing heating circuits**

They run with a weekly program which allows many time windows and automatic and/or manual additional functions. The system can optionally be expanded with room sensors and remote control.



Comprehensible also without the need for an operating manual: The symbols on the touchscreen are self-explanatory. So controlling the heating system becomes child's play.

Additional system functions

Detection of third-party heating devices, such as oil boilers, gas boilers, heat pumps and wood burning stoves, thermostat or differential temperature thermostat, external demand from external devices such as heating fans, control of transmission lines, with or without mixers, and also of heat transfer stations, single room control systems, for example.

Wall-mounted control box for more complex systems

All control systems can be extended with wall-mounted control boxes, with or without touchscreen.

*Control system and sensor included in standard delivery scope

**Control system depends on configuration, sensors are available as accessory

From Hausruckviertel to the world

ETA specialises in the manufacture of biomass heating, i.e. log, pellet and wood chip boilers. The most modern technologies combined with naturally growing resources.

ETA is efficient

Technicians designate the efficiency of a heating system with the Greek letter η , pronounced „eta“. ETA boilers stand for more heat with less fuel consumption, environmental soundness and sustainability.

Wood: old but excellent

Wood is our oldest fuel - and our most modern: There is a lot of history - from open fires in front of caves to modern biomass boilers. In the middle of the 20th century, the number of wood heating systems briefly fell. Oil heating became the new, hyped option. A brief interlude in comparison to the consistency of wood. Today, we know that heating with fossil fuel has no future. It contributes to global warming and harms the environment. Supply security is also not guaranteed in the long term, as fossil fuels are being depleted, aren't renewable and often come from unstable regions. While wood by contrast is a cheaper, locally grown, renewable raw material that does not pollute the climate when burnt. No wonder wood heating is booming!

Comfort with many components

Since December 1998, the Upper Austrian company ETA has been designing and building a new generation of wood-fired boilers. They are full of patented technologies and the most modern control technology – making them easy to use. Convenience and efficiency make ETA products so popular around the world. With a production capacity of up to 35,000 boilers per year and a global export proportion of around 80%, ETA is one of the leading biomass boiler producers.

You get more than just a boiler

Anyone who decides on a wood or pellet boiler from ETA is choosing sustainability. This is not just in terms of fuel, but encompasses responsibility across the board, with sustainable workplaces in the region. More than 400 employees in Hofkirchen an der Trattnach have the best working conditions – including an in-house restaurant, bright assembly and storage halls, a fitness room and a sauna. There is even a free electric charging station for electric cars, which is supplied by the in-house photovoltaic system. This also covers all the power needed of a production hall and thus saves around 230 tonnes of CO₂ per year.

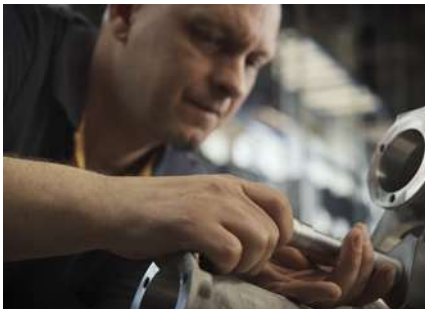

Pellets boiler ETA ePE BW 8 to 14 kW

- 1** Pellets suction and return air connections DN50
 - 2** Drain for the safety valve, Union nut, flat sealing R1"
 - 3** Flow, union nut flat sealing R3/4"
 - 4** Return, union nut flat sealing R3/4"
 - 5** Air connection for operation with external air supply, NW80
 - 6** Flue gas connection \varnothing 113 and 130
 - 7** Outlet for condensate, DN 50
- X = dimension variable, depending on the chimney connecting pipe

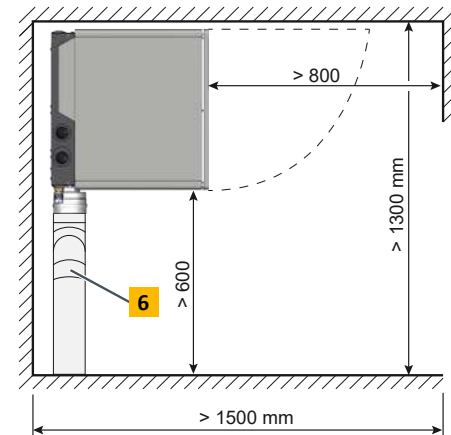
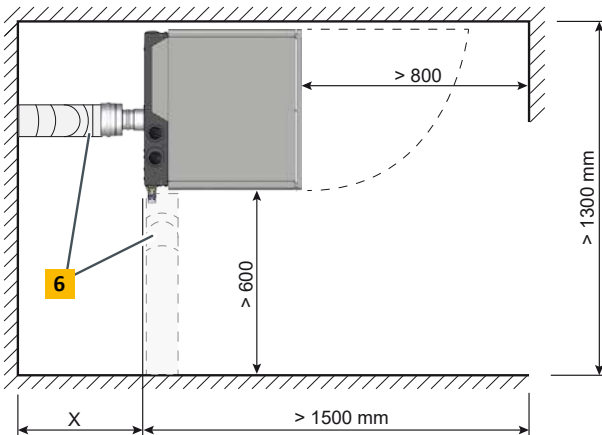
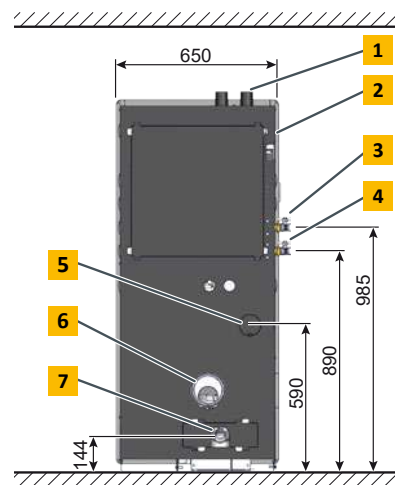
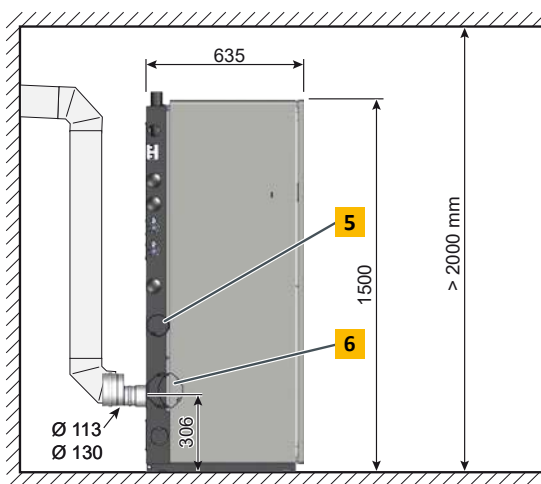



Pellet Condensing Boiler ePE BW		8	10	12	14
Rated capacity (with condensing operation)	kW	2,4 - 8	3 - 10	3,6 - 12	4,2 - 14
Rated capacity (non-condensing operation)	kW	2,3 - 7,6	2,9 - 9,5	3,4 - 11,4	4 - 13,3
Energy efficiency class**		A++			
Flue gas losses (with condensing operation) at partial / full load*	%	104,8 / 104,7	104,7 / 104,5	104,6 / 104,3	104,6 / 104,3
Flue gas losses (non-condensing operation) at partial / full load*	%	98 / 98			
Transport dimensions, W x D x H	mm	650 x 635 x 1.550			
Weight	kg	270			
Water volume	Liter	41			
Free residual pump head of the integrated mixing circuit at $\Delta T=7^\circ\text{C}$ for operation with a buffer or radiators	mWS / m^3/h	7,3 / 0,34	7,1 / 0,43	6,8 / 0,52	6,2 / 0,60
Free residual pump head (at $\Delta T = 7\text{ K}$) for underfloor heating circuit operation. With underfloor heating circuit operation, the maximum output is 14 kW.	mWS / m^3/h	5,7 / 0,98	4,6 / 1,23	3,4 / 1,48	2,3 / 1,72
Maximum distance to pellet store	m	20			
Ash box volume	Liter	13,5			
Required flue draught	Pa	0 Pa up to 3 Pa positive pressure in the fluegas line ist permitted			
Electrical power consumption at partial / full load* (= Values with integrated particle precipitator)	W	28 / 36 (44 / 60)	28 / 38 (46 / 62)	28 / 40 (48 / 64)	28 / 43 (46 / 64)
Electrical power consumption in ready mode*	W	7			
Maximum permissible operating pressure	bar	3			
Temperature adjustment range	$^\circ\text{C}$	30 - 90			
Boiler class		5 according to EN303-5:2018			
Suitable fuels		Pellets ISO 17225-2-A1, ENplus-A1			
Electrical connection		1 x 230V / 50 Hz / 13 A			

*Data from test report

**Energy labelling for packages (solid fuel boiler + temperature control)

Technical changes and mistakes reserved!



Complies with
EU standards



Austrian Ecolabel

Pellets boiler ETA ePE BW 16 to 22 kW

- 1** Pellets suction and return air connections DN50
 - 2** Drain for the safety valve, union nut, flat sealing R1"
 - 3** Flow, union nut flat sealing R1"
 - 4** Return, union nut flat sealing R1"
 - 5** Air connection for room air-independent operation, NW80
 - 6** Flue gas connection \varnothing 130
 - 7** Drain for condensate, DN50
- X = dimension variable, depending on the chimney connecting pipe

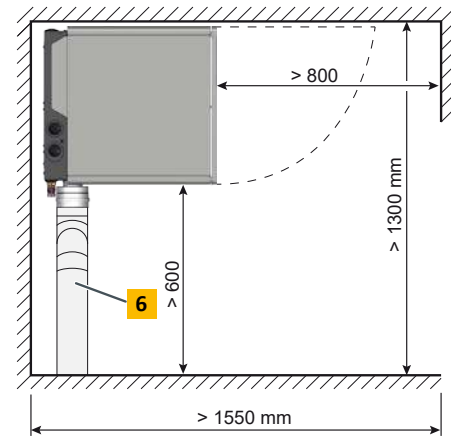
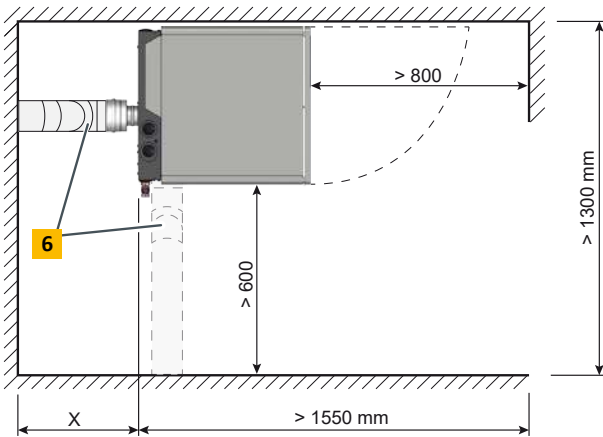
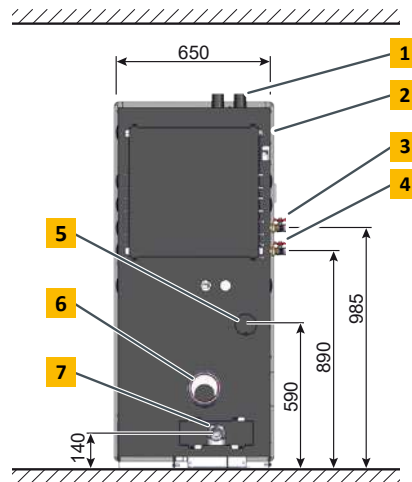
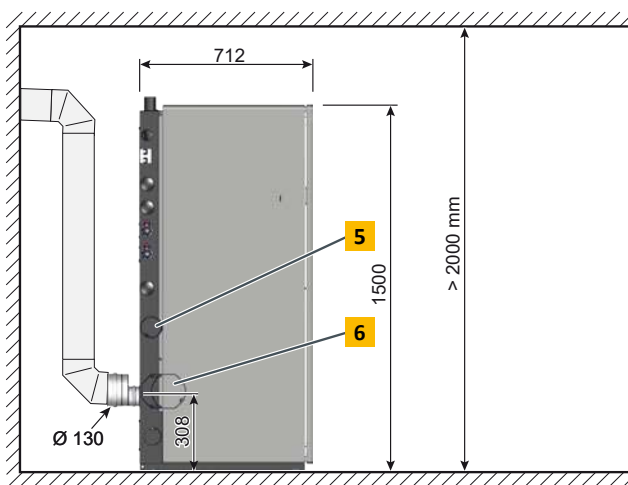



Pellet Condensing Boiler ePE BW		16	18	20	22
Rated capacity (with condensing operation)	kW	4,8 - 16	5,4 - 18	6 - 20	6,6 - 22
Rated capacity (non-condensing operation)	kW	4,6 - 15,2	5,1 - 17,1	5,7 - 19	6,3 - 21
Energy efficiency class**		A++			
Flue gas losses (with condensing operation) at partial / full load*	%	104 / 104	104 / 104	104 / 104	104,6 / 104,3
Flue gas losses (non-condensing operation) at partial / full load*	%	98 / 98	98 / 98	98 / 98	97,3 / 98,3
Transport dimensions, W x D x H	mm	660 x 721 x 1.580			
Weight	kg	272			
Water volume	Liter	49			
Free residual pump head of the integrated mixing circuit at $\Delta T=7^\circ\text{C}$ for operation with a buffer or radiators	mWS / m^3/h	7 / 0,69	6,7 / 0,78	6,3 / 0,86	5,9 / 0,94
Free residual pump head (at $\Delta T = 7\text{ K}$) for underfloor heating circuit operation. With underfloor heating circuit operation, the maximum output is 14 kW.	mWS / m^3/h	2,5 / 1,72			
Maximum distance to pellet store	m	20			
Ash box volume	Liter	15			
Required flue draught	Pa	0 Pa up to 3 Pa positive pressure in the fluegass line ist permitted			
Electrical power consumption at partial / full load* (= Values with integrated particle precipitator)	W	28 / 46 (43 / 64)	28 / 50 (41 / 64)	28 / 53 (38 / 64)	28 / 56 (36 / 64)
Electrical power consumption in ready mode*	W	7			
Maximum permissible operating pressure	bar	3			
Temperature adjustment range	$^\circ\text{C}$	30 – 90			
Boiler class		5 according to EN303-5:2018			
Suitable fuels		Pellets ISO 17225-2-A1, ENplus-A1			
Electrical connection		1 x 230 V / 50 Hz / 13 A			

*Data from test report

**Energy labelling for packages (solid fuel boiler + temperature control)

Technical changes and mistakes reserved!



Complies with
EU standards

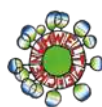

Austrian Ecolabel

NOTES

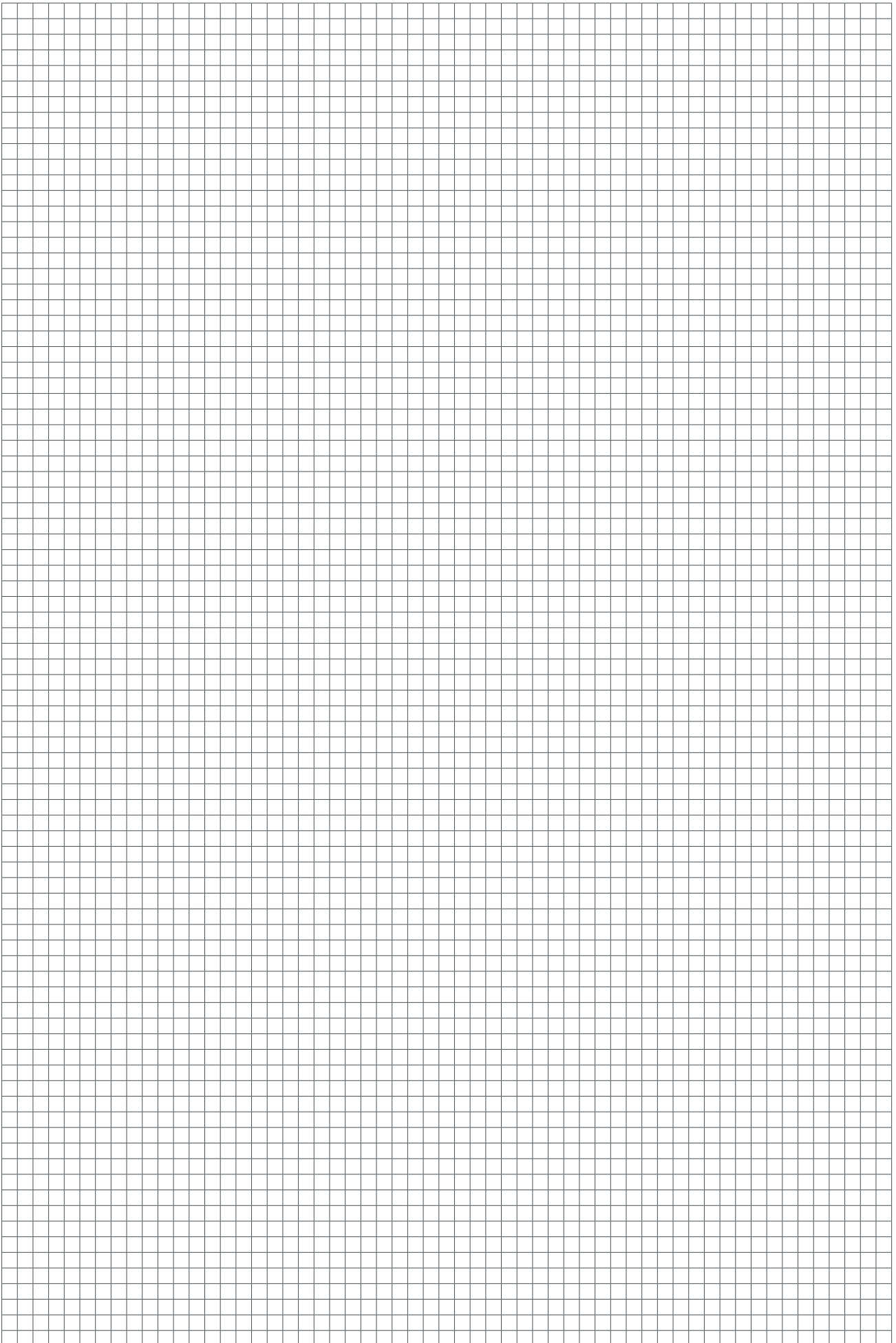

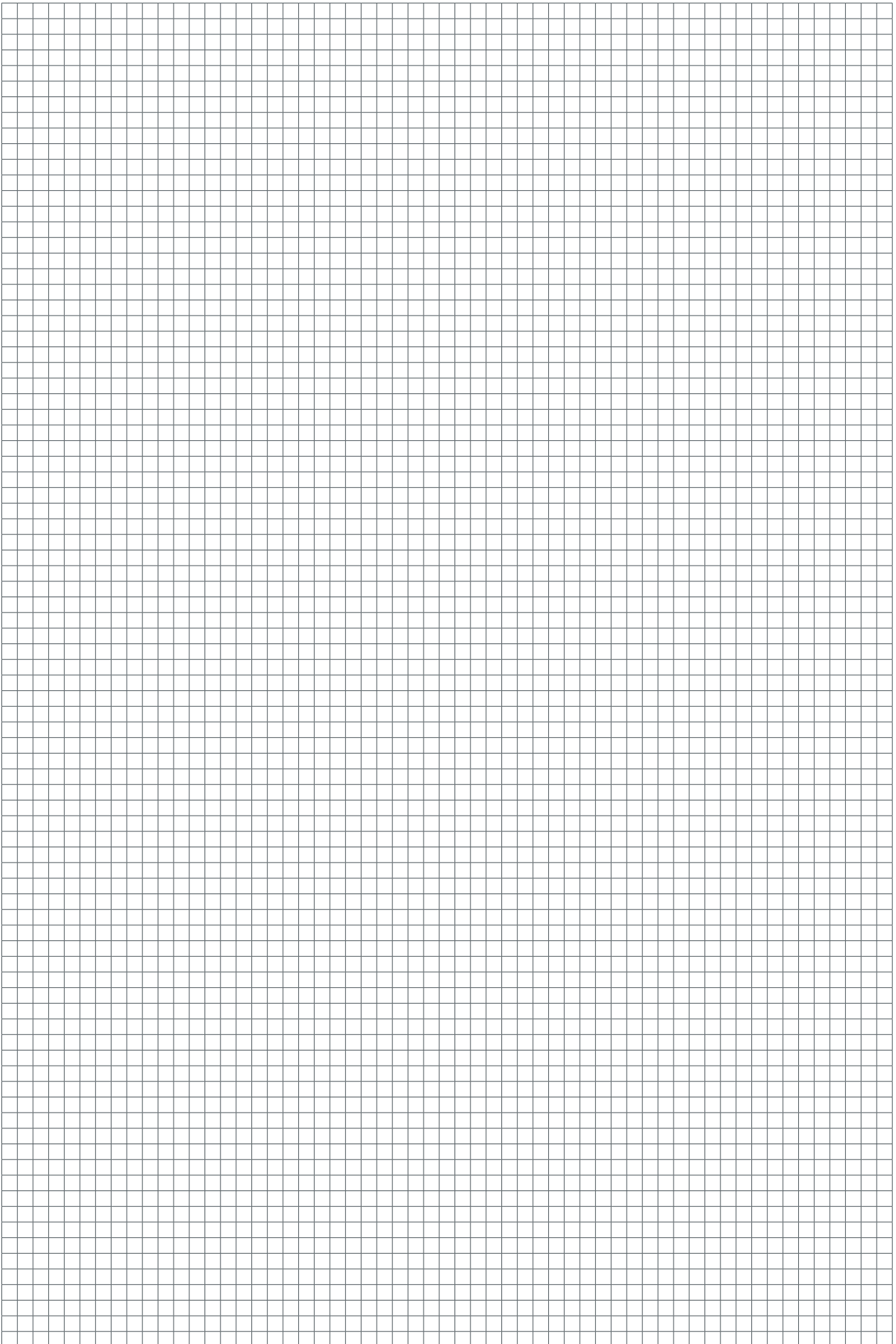



ETA Pelletboiler

ETA PU PelletsUnit	7 - 15 kW
ETA ePE pellet boiler	7 - 20 kW
ETA PC PelletsCompact	20 - 105 kW
ETA ePE-K pellet boiler	100 - 240 kW



ETA condensing heat technology

ETA ePE BW pellet boiler	8 - 22 kW
ETA BW condensing heat exchanger PU	7 - 15 kW
ETA BW condensing heat exchanger PC	20 - 105 kW



ETA SH log wood boiler and TWIN pellet boiler

ETA SH log wood boiler	20 - 60 kW
ETA SH-P log wood boiler	20 - 60 kW
with ETA TWIN pellet boiler	20 - 50 kW



ETA wood chip boiler

ETA eHACK wood chip boiler	20 - 240 kW
ETA HACK VR wood chip boiler	250 - 500 kW



ETA buffer tank

ETA buffer	500 l
ETA buffer tank SP	600 - 5.000 l
ETA buffer tank SPS	600 - 1.100 l

ETA hydraulic modules

- ETA fresh water module
- ETA stratified charging module
- ETA system separation module
- ETA mixing circuit module
- ETA heat transfer module and station

Your heating specialist will be happy to advise you:



ETA Heiztechnik GmbH
 Gewerbepark 1
 A-4716 Hofkirchen an der Trattnach
 Tel.: +43 7734 2288-0
 Fax: +43 7734 2288-22
 info@eta.co.at
 www.eta.co.at

Technical changes and mistakes reserved

In order to provide you the benefits of our continuous development, we reserve the right to change specifications without prior notice. Printing and typesetting errors or changes of any kind made in the interim are not cause for claims. Individual configurations depicted or described here are only available as options. In the event of discrepancies between individual documents regarding the scope of delivery, the information provided in our current price list shall prevail. Images and symbols may contain options that are available for an additional cost.

Photo source: ETA Heiztechnik GmbH, Lothar Prokop Photographie, istockphoto, Thinkstockphotos, Photocase, Shutterstock.
 94740-EN, Prospekt ETA ePE BW EN, 2023-02

