

Pellet Boiler
ETA ePE 7-20 kW



... my heating system



Compact pellet boiler for single family houses and apartment buildings



A passion for perfection.

www.eta.co.at



The flexible little one with a big heating effect

With a footprint of less than half a square metre, the ETA ePE pellet boiler offers excellent energy efficiency, maximum safety and the best possible ease of use. Even a precipitator, which filters out fine dust, can be integrated into the compact, visually appealing device.

And the ePE pellet boiler from the Upper Austrian high-quality manufacturer ETA doesn't just heat newly constructed single-family houses and apartment buildings in a cost-effective and environmentally friendly way: the space-saving technological miracle is also ideal as a replacement for an old boiler. Thanks to the flexible connection options, the ePE pellet boiler can be easily integrated into existing heating systems. Since it can be operated independently of the room air by drawing oxygen from outside instead of from the room itself, you can set it up anywhere - even in very well insulated living rooms, for example.

Efficient and safe

Like all high-quality products from ETA, the ePE pellet boiler is highly efficient. The combustion chamber and heat exchanger are cleaned automatically on a regular basis to ensure that no residue impairs the heating result. Furthermore, a draught fan and a lambda probe ensure that the combustion chamber is always supplied with the optimum amount of oxygen for ideal combustion. The burn-back protection with rotary valve guarantees that the fire stays safely in the combustion chamber.

More convenience, less work

The combustion chamber of the ePE pellet boiler is automatically de-ashed. The ash is compressed and collected in an easily accessible container that can be emptied with very little effort.

For the sake of the environment

Heating with pellets is extremely environmentally friendly. Leftovers from the wood processing industry are used as fuel. The climate is not harmed because the combustion of wood does not release more CO₂ than what the tree previously absorbed while growing. Optionally, the ePE pellet boiler also has an additional environmental benefit: a precipitator. This ensures that the fine dust produced during combustion does not escape, but instead ends up in the ash bin.

A win-win situation

Save heating costs, boost your domestic economy and help the environment in the process: heating with pellets pays off. Currently, around 7 million cubic metres of excess wood is growing in Austria - and forested areas are increasing across the whole of Europe.

Using resources sensibly

In contrast to fuels such as oil and gas, pellets hardly effect the climate. That is because trees absorb as much CO₂ during growth as they later release during combustion. In addition, the CO₂ released when burning is equal to or less than that of naturally rotting wood.

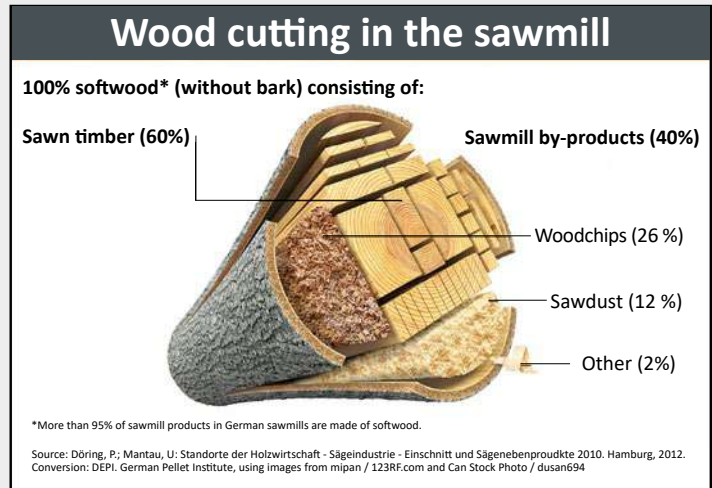

No extra trees have to be felled to produce pellets, because the wooden briquettes consist mainly of sawdust, a waste product of the wood industry.

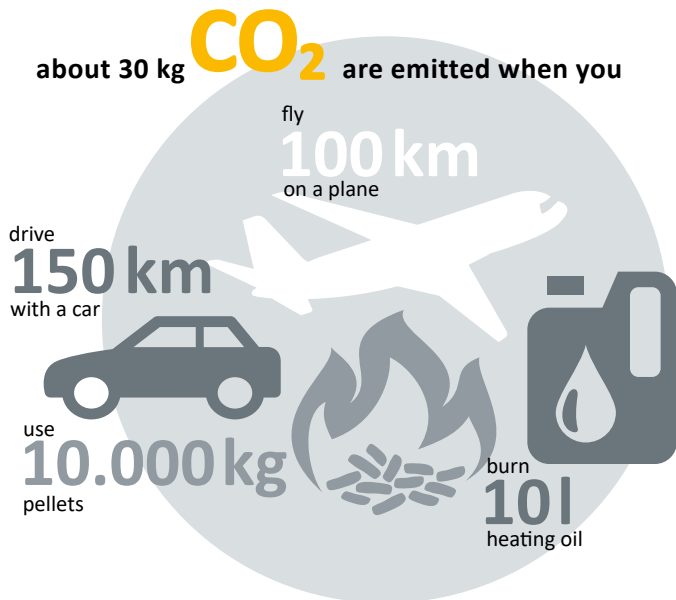

Oil in comparison

Calculation period: 5 years



Fuel costs: Oil and pellets in comparison

2 tonnes of pellets roughly correspond to 1,000 litres of heating oil

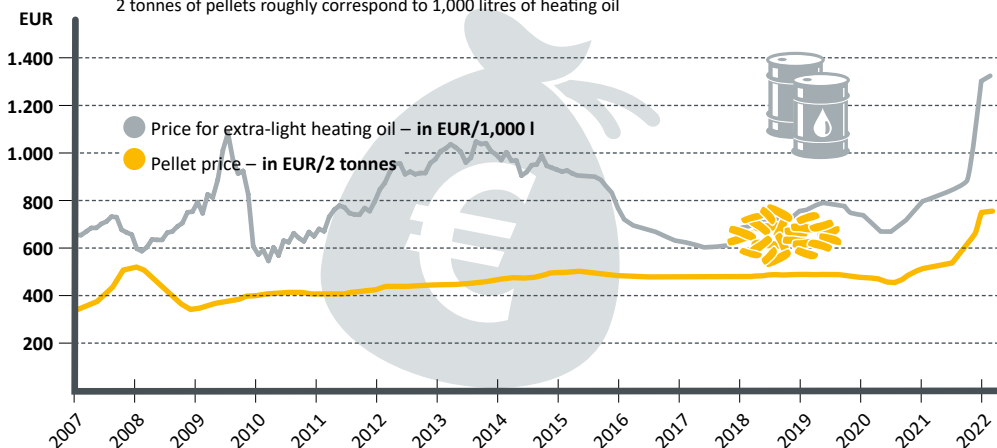

Always space for pellets

The pellet store can easily be set up where the oil tank was situated previously. It can be located up to 20 metres and two floors away from the boiler. If you don't have space in the house, the store can also be set up in an ancillary building, or an underground tank can be used. The store room just needs to be dry so that the pellets don't expand. Wooden cladding can help in rather damp rooms.

Attractive also for complete renovations and new builds: with a well-insulated house, 6 m² is often sufficient for the heating and pellet storage room.



A clean solution

The small rolls, which are pressed from the waste products of the wood industry, are delivered by tanker and blown into the store room. Thus, the delivery of pellets is an extremely clean process. As long as the store itself is tight, no dust will escape.

or approx 4 tonnes of pellets, per year. When moving from another energy source to pellets, the pellet requirement can also be determined from the previous consumption.

How big does my storage room have to be?

The approximate pellet requirement per year in tonnes is calculated by dividing the heating load in kilowatts by 3. To calculate the pellet requirement in cubic meters, divide the heating load by 2. For example for a 12 kW heating load, you need 6 m³,

One tonne of pellets roughly corresponds to:

- 500 l heating oil
- 520 m³ natural gas
- 750 l LPG
- 600 kg coke
- 1,400 kWh electricity with geothermal heat pumps (practical coefficient of performance 3.4)
- 2,700 kWh electricity with air heat pumps (practical coefficient of performance 1.8)

How do the pellets get to the boiler?

Discharge screw:

It stretches the entire length of the store room, can be up to 6 m long and transports the pellets from the store room to the transport hoses, which lead to the boiler. From here, the pellets are transported further by means of the integrated vacuum turbine. After transport, the hoses are vacuumed empty. Hence they do not clog up and always work with the highest degree of efficiency. With this standard system, the storage room can be completely emptied. The pellets

automatically slide to the transport screw over the inclined smooth floor. The impact protection mat is suspended opposite the filling nozzles, so that the pellets do not shatter on the wall when they are blown into the storage room from the truck. A requirement for this construction is that the connections for the transport hoses to the boiler are located on the narrow side of the storage room, so that the whole length of the room can be utilized.

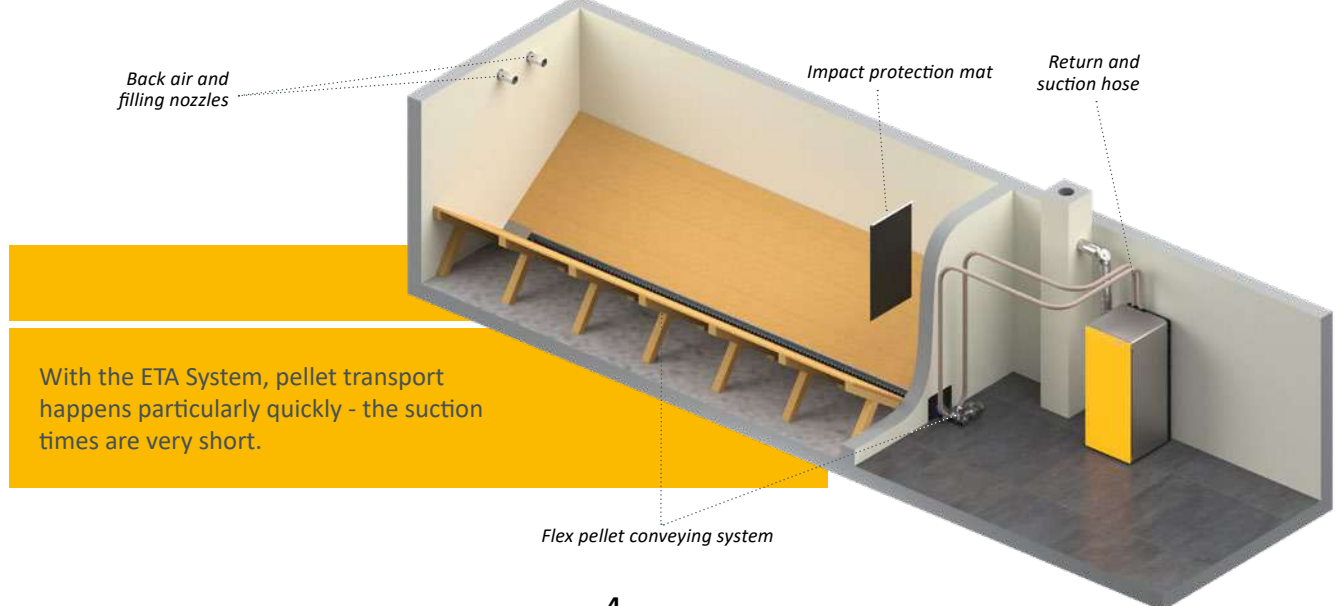

With the ETA System, pellet transport happens particularly quickly - the suction times are very short.

Suction probes:

If the shape of the room is not suitable for a discharge screw, the ETA suction probe system can be used instead. Here, the pellets slide over the slanting and smooth wooden floor directly to the four - or eight - suction probes, which alternately transport pellets away from the storeroom. Through automatic switching, the fuel supply is not interrupted if a probe does not get any pellets at a certain point in time. A prerequisite for this system is that the store room is situated opposite the boiler in the same

storey or higher, and that the store room is no longer than 4 m. Longer rooms can be used if you opt for the 8-way switching unit instead of the 4-way unit. Unlike the screw, suction probes do not fully empty the storage room. When the storage room capacity is tight, this can be a disadvantage. The advantage is that this system can be used even in angled store rooms.



With suction probes, even irregularly shaped spaces can be used as pellet stores

Mole conveying system:

This is ideal when the storage area is small compared to the required amount of pellets, because here you do not need a slanted floor and can therefore utilize the entire storage volume. The mole, a device that sucks in the pellets from above, gets into every corner and thus empties even irregularly shaped rooms almost completely.



ETA tip: Storage in an ETAbox

The ETAbox is a particularly practical solution. It can be set up directly in the boiler room, in the attic, in a barn or – if covered – even outside. It even keeps the pellets dry in damp rooms. Distances of up to 20 meters of suction stretches from the box to the boiler are no problem. The ETAbox cannot be set up directly on the wall, however. Which is why the space required is a bit larger compared to a brick store with the same capacity.

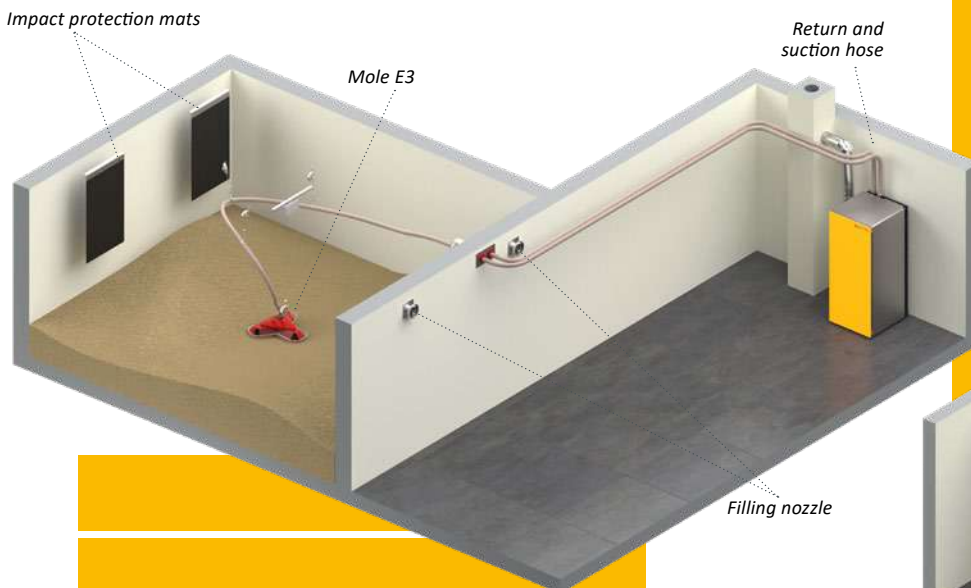

The mole discharge is the perfect choice if you want to store large amounts of fuel in a small space.



Heat, just the way you need it

The ETA ePE doesn't just produce heat, the ETA System also distributes it efficiently. Rely on the perfect control centre for your heating and hot water system.

The ETA ePE is equipped with a control system for the entire heating system. Whether you want to integrate a solar heating system, a conventional hot water preparation system or a buffer storage tank with fresh water module, and whether the energy is transferred with radiators or via floor or wall heating: everything is controlled from a touchscreen on the boiler or a computer or smartphone. Simple images show you if your solar heating system was successful or how full your buffer is.

Perfect with a buffer

The ETA buffer tank is your perfect partner. Especially when heating in autumn or in spring and for hot water preparation in the summer, less energy is often required than the boiler produces. The buffer stores this excess heat and releases it on demand. This saves fuel and protects the boiler,

because fewer boiler start-ups are required. The ETA stratified buffer is ideal for the integration of a solar heating system. In summer, hot water can be produced at virtually no operating costs. But in winter, the solar collectors seldom produce the 60 °C that are common for hot water preparation. Then the water that is heated by solar energy is fed through the underfloor or wall heating. This usually works with heating water temperatures of just 30-40 ° C.

Remote controlled via the meinETA communication platform



Be it a solar heating system, hot water preparation or a buffer storage tank with a fresh water module: the whole solar heating system can be easily controlled from the boiler display.





Everything at a glance!
The ETA room sensor displays the room temperature and the outside temperature and enables a simple change of the desired room temperature.

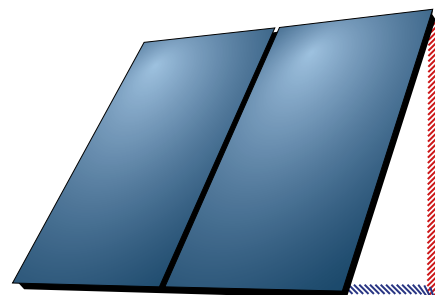

For smaller solar heating systems with large buffer storage tank volumes or for very large solar heating systems, the ETA stratified charging module ensures maximum efficiency.

ETA individual room temperature control
A pleasant temperature, one room at a time

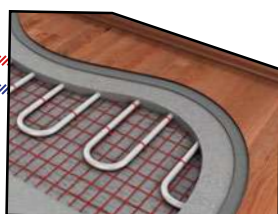

Direct connection of a heating circuit from the boiler without external pumps in the boiler room.

The ETA stratified buffer can also be equipped with a fresh water module, which constantly reheats the tap water with the help of a heat exchanger. Thus the risk of germs and bacteria is minimised.



An ETA stratified buffer is the ideal addition to the ePE. It stores energy that is not required and delivers it on demand.

Safe, reliable and easy to use

When selecting a new heating boiler, you are making a decision that can have an effect on your daily life for many years. You determine how safe you can feel and how much you have to worry about maintenance and cleaning. This is where quality at a fair price pays!

Automatically clean

The ETA ePE cleans itself automatically – and not just at certain intervals, but precisely when it's needed. This ensures low emission values and the highest degree of efficiency during the heating season. You never have to open the combustion chamber and get yourself dirty. Not only is the combustion chamber de-ashed cleanly, the heat exchanger is also regularly cleared of deposits. As the pellets are burnt very efficiently, less ash is produced. In addition, the ash is compacted in the container. Which is why the ash box only needs to be emptied occasionally. And this is easily done from the outside.

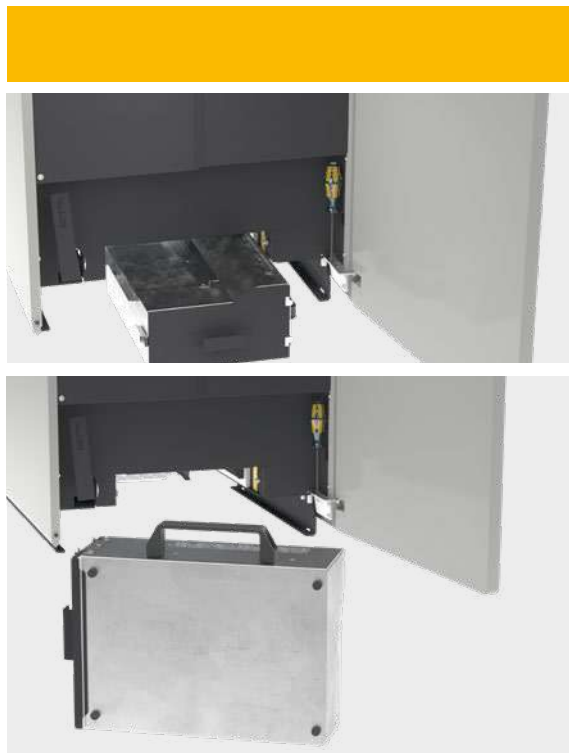

Rotary valve

The safe system. The rotary valve absolutely protects you from burn-back: burning should only take place in the combustion chamber and nowhere else.

A dosing screw transports the pellets to the rotary valve – and only as many as the rotary valve can handle. This is why the pellets do not become wedged, crushed or broken. Thanks to this system developed by ETA, the sealed edges of the rotary valve do not wear out. The system remains safe throughout the entire service life of the boiler.

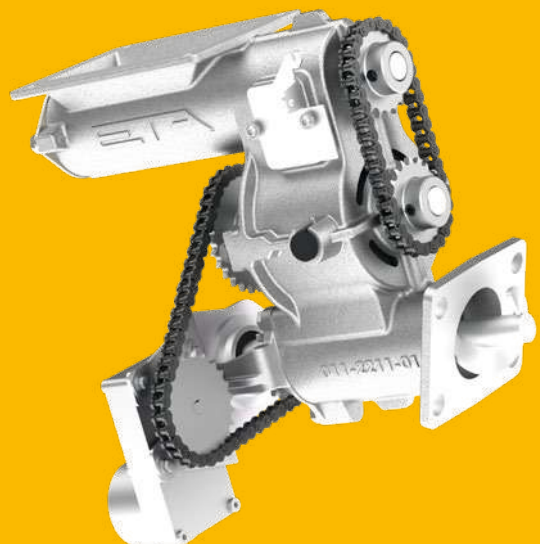



Rear view of the boiler
You can find more information under "Technical data"

Flexible connection options

Quickly set up anywhere.

Thanks to the flexible connections for hydraulics, flue pipe and supply air, you can install the ETA ePE not only against the wall, but also in a corner. During installation, the hydraulic connections can easily be turned to the left or right in the desired direction, and the supply air and flue gas connections are optionally on the left or rear.

Operation with external air supply.

The ETA ePE can take the oxygen required for combustion from outside instead of from the ambient air inside. This means the boiler can also be located within a heated building shell, without having to permanently open a window in the deepest of winter.

Noiseless ceramic igniter

Sparking technology. The energy expended in ignition is much lower in comparison with other ignition systems. The ignition itself works quicker.

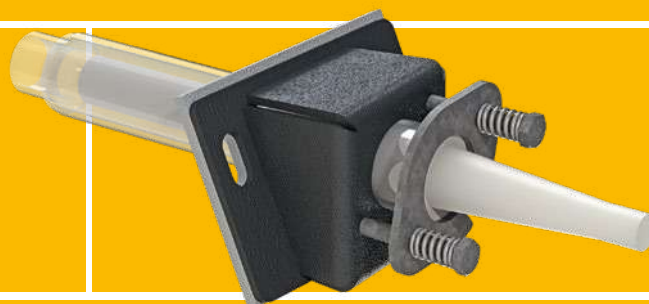

Lambda probe

It's all about the mix. With its help, the mixing ratio of fuel and oxygen are perfectly matched. As a result, different pellet qualities achieve the best possible efficiency at all times. In addition, the probe immediately detects if the ignition was successful. This reduces the ignition time and saves electricity and money.

Control system

Versatile, yet simple.

Whether furnace control, pellet conveying, buffer management, hot water preparation, weather-controlled heating circuit controlled with a weekly program for two circuits or the connected solar heating system: all of this can be controlled via a touchscreen directly on the boiler or via the internet from any PC, smartphone or tablet. It is a lot, but it is easy to handle as the images on the touchscreen are self-explanatory.





The way to heat

From pellet hopper to combustion chamber to pump: the interplay of high-quality components is needed!

- 1 Vacuum motor:** It transports the pellets from the storage room to the intermediate container of the boiler.
- 2 Pellet bin:** Here, 30 kg of pellets are stored temporarily and are immediately available for use. So pellets have to be transported from the store room to the boiler only once or twice a day for 10 minutes. You control when.
- 3 Rotary valve as a burn-back protection device:** It is a completely sealed closing door between the storeroom and ignition and, therefore, safely protects against burn-back.
- 4 Automatic de-ashing in the ash box:** The small amount of ash that still falls despite the optimised combustion processes is firmly compacted in the ash bin. So the ash bin needs to be emptied less often. When it's time for this, the boiler sends a reminder by email.
- 5 Lambda probe:** With this device the mixing ratio of fuel and oxygen is perfectly adjusted. So different pellet qualities always achieve the best possible efficiency.
- 6 Safety devices:** A safety valve and an electronic pressure sensor protect the boiler from overpressure. An automatic rapid bleed valve is also integrated to remove unwanted air from the hot water circuit. The boiler does not need a thermal safety valve, as there is never too much fuel in the boiler that could cause overheating.





The way through the boiler:

-  Flue gases
-  Heating water

- 7 Precipitator:** The optional integrated precipitator reduces the dust load in the flue gas to a minimum. The environment loves it!
- 8 Mixer:** Thanks to the interchangeable servomotor, it can be perfectly adapted to the existing or planned hydraulic system.
- 9 Pump:** It is speed-controlled, highly efficient, energy-saving and ensures the movement of the heating water. Depending on the system type, it is either the heating circuit pump for an underfloor heater or radiator heating or it handles buffer charging.
- 10 Combustion chamber:** Here, temperatures are produced that are high enough to burn wood cleanly and efficiently. This ensures less ash and low emissions, even under partial load.
- 11 Heating circuit:** The optional integrated heating circuit is installed in the boiler to save space. This means that no mixer or pump has to be installed externally in the boiler room for this heating circuit.



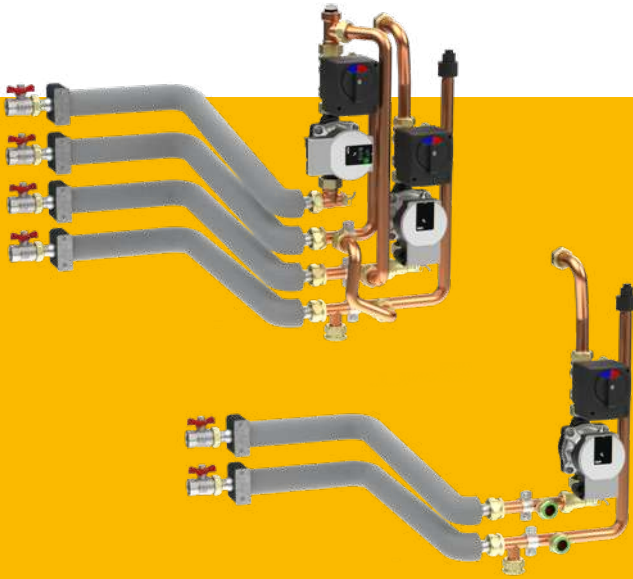

All-in-one

The most important elements for heat distribution, such as pumps, mixers and shut-off devices, are also integrated in the boiler, as are safety valves, pressure gauges and bleed valves.

The installation of a mixer heating circuit is also possible as an option. This saves space and makes assembly easier.

Draught fan

Underpressure in the boiler. Quiet as a whisper, the speed-controlled fan ensures underpressure in the boiler and determines the air quantity for the combustion. It ensures consistent combustion results while saving energy – largely independent of the condition of the chimney.



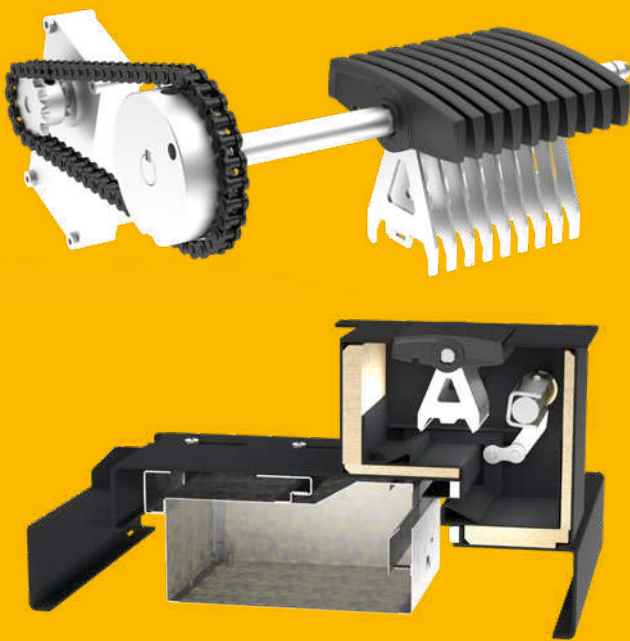

Revolving grate with cleaning comb

Clean burns well. This patented system cleans the combustion chamber regularly of ash – always automatically after a certain amount of pellets have been burnt. The air required for the combustion process is distributed extensively between the clean grate segments. Additionally, the grate is constantly kept in slight motion. The gentle movement stokes the firebed and thus ensures even better combustion.

The ash is compacted and ends up in the ash box. Even at full load operation, the boiler only has to be emptied from time to time. When it is time, the system sends an email or an SMS message. The information is also displayed on the touch display.

Precipitator

Clever use of a natural phenomenon

Why does dust keep building up on the computer screen? It is because the dust particles are electrostatically charged and are attracted by the screen. – ETA makes use of this effect in its precipitator. With the aid of an electrode in the flue gas duct the particles which are swirling in the flue gas are energised and ionised. They are deposited on the internal wall of the separator and can no longer escape from the chimney with the flue gases.



The optional precipitator makes heating with wood even cleaner and more environmentally friendly. It extracts the dust from the flue gases by means of electric current.



Away mode, set-back mode, vacation setting: intuitively, you know immediately which button does what.

Easy to control from anywhere

Good technology is characterised by its user friendliness. You don't have to be a technician to use the many functions of the ETAtouch.

ETAtouch: the touchscreen on the boiler

Confusingly arranged buttons and control systems are a thing of the past, because with the touchscreen of the ETA PelletsUnit you can quickly and easily control every setting. The icons are self-explanatory. Whether you generally want to make it warmer or cooler, change the time for set-back mode or want to switch to eco mode during your vacation - you will tap on the right symbol intuitively and entirely without reading operating manuals!

You not only control your boiler via the touchscreen, but also have an overview of all connected components, such as buffer storage tank, pellet store, solar heating system or domestic hot water preparation. You know straightaway, for example, how many pellets you still have in store or how effective your solar heating system was.

meinETA: the free internet platform

If your boiler is connected to the internet, you can see and change all heating settings on your mobile, tablet or PC. So you always have a handle on your heating, wherever you are! When you login to www.meinETA.at, you see the touchscreen as if you were standing right in front of the boiler! The pellet store needs filling, the ash bin must be emptied, it's time for the next heating service... You don't have to remember all these things yourself. meinETA reminds you for free by email.

You can control the boiler via smartphone, PC or tablet as well as directly on the touchscreen.



Quick help

Give your installer or the ETA customer service representative temporary access rights to your meinETA account. So they can prepare for their visit to you. And maybe the technician doesn't even have to visit, because thanks to meinETA they can tell you over the phone what you need to do to make your boiler work again. You can see who can access your boiler via the status display. Only you decide who's in your partner network!

For tablet, smartphone and PC

meinETA runs on all current operating systems, such as iOS or Android. Via PC, meinETA can be loaded by any modern internet browser, such as Mozilla Firefox, Safari, Google Chrome or Internet Explorer 9.



Technical requirements for meinETA

In order to use meinETA, you need a broadband internet connection in the house. The boiler's touchscreen is connected to the Internet via a network cable. If you don't have a network connection in the basement, simply connect via the ETA PowerLine. It conveniently transmits the data to the modem via any socket.

As convenient as an app -
for free and with
full functionality on
the heating system!

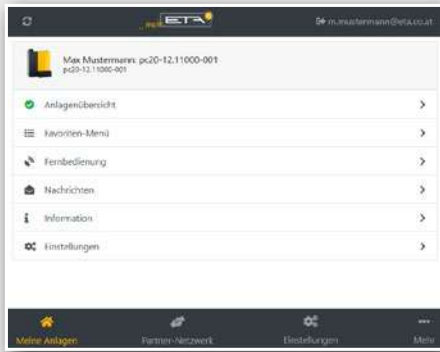

User interface of the meinETA platform



It's all very simple

mein ETA system 2.0 is now even more convenient to use. Simply register once, as with an app, and use all functions without restrictions and free of charge.

LOXONE



KNX
Interface



Perfect for your smart home

The ETAtouch control system can be easily integrated into standard smart home systems and into a building management system (BMS). The miniserver of the Loxone system exchanges data directly with the boiler via a ModbusTCP interface. Even when connecting to a KNX bus system, all it takes is the optionally available ETA KNX interface and a few simple clicks.

ETA individual room temperature control interface example

Whether Loxone, KNX or ETA individual room sensor with or without display: everything can be controlled via ETAtouch. It always sends the correct signals to the valve controllers, which control how much hot water should get through to the respective room or heating section.

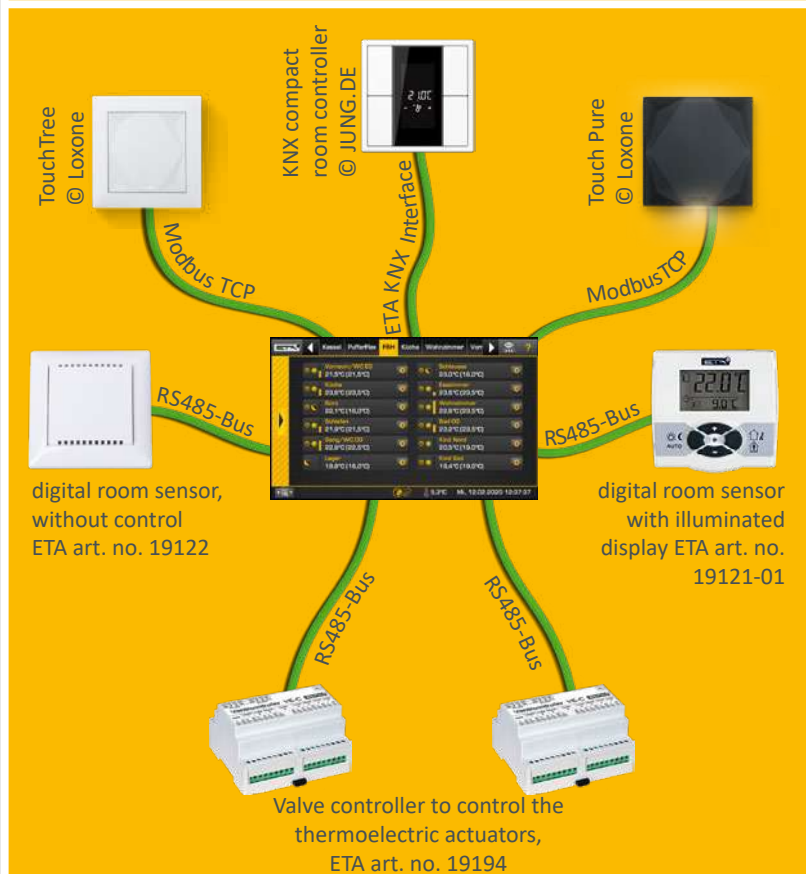

Everything on one display: the ETA Standard

A modern heating system is only effective if it is well-controlled. ETAtouch takes care of that.

At no added cost, the ETAtouch control system already includes all functions for two heating circuits, hot water supply via tank or instantaneous hot water module, as well as for the integration of a solar heating system. All ETA heating boilers also come with a LAN connection as standard. If you connect the boiler to the internet, you can easily control all components from a PC, tablet or smartphone.

Boiler and combustion regulation*

Speed-controlling the several components save power. The lambda and ignition time regulation increases efficiency. All components relevant to operation are monitored.

Buffer storage tank management**

Three to nine sensors in the tank control the heat generator in the system and distribute the energy to the different consumers. From using five sensors, cascading regulation, QM-Holz and peak load management are part of the ETA Standard.

Domestic hot water preparation*

Is made possible both via the ETA instantaneous hot water module but also via the hot water tank or combination tank. For all variants, circulation pumps can be controlled with time and/or requirement programs.

Solar heating systems**

Single or double circuit solar heating systems with one or two tanks, zone loading via the ETA stratified charging module and also two collector fields as well as three consumers are controlled.

Two weather-controlled mixing heating circuits**

They run with a weekly program which allows many time windows and automatic and/or manual additional functions. The system can optionally be expanded with room sensors and remote control.

* Control system and sensor included in standard delivery scope

** Control system depends on configuration, sensors are available as accessory



Comprehensible also without the need for an operating manual: The symbols on the touchscreen are self-explanatory. So controlling the heating system becomes child's play.

Additional system functions

Detection of third-party heating devices, such as oil boilers, gas boilers, heat pumps and wood burning stoves, thermostat or differential temperature thermostat, external demand from external devices such as heating fans, control of transmission lines, with or without mixers, and also of heat transfer stations, single room control systems, for example.

Wall-mounted control box for more complex systems

All control systems can be extended with wall-mounted control boxes, with or without touchscreen.

From Hausruckviertel to the world

ETA specialises in the manufacture of biomass heating, i.e. log, pellet and wood chip boilers. The most modern technologies combined with naturally growing resources.

ETA is efficient

Technicians designate the efficiency of a heating system with the Greek letter η , pronounced „eta“. ETA boilers stand for more heat with less fuel consumption, environmental soundness and sustainability.

Wood: old but excellent

Wood is our oldest fuel - and our most modern: There is a lot of history - from open fires in front of caves to modern biomass boilers. In the middle of the 20th century, the number of wood heating systems briefly fell. Oil heating became the new, hyped option. A brief interlude in comparison to the consistency of wood. Today, we know that heating with fossil fuel has no future. It contributes to global warming and harms the environment. Supply security is also not guaranteed in the long term, as fossil fuels are being depleted, aren't renewable and often come from unstable regions. While wood by contrast is a cheaper, locally grown, renewable raw material that does not pollute the climate when burnt. No wonder wood heating is booming!

Comfort with many components

Since December 1998, the Upper Austrian company ETA has been designing and building a new generation of wood-fired boilers. They are full of patented technologies and the most modern control technology – making them easy to use. Convenience and efficiency make ETA products so popular around the world. With a production capacity of up to 35,000 boilers per year and a global export proportion of around 80%, ETA is one of the leading biomass boiler producers.

You get more than just a boiler

Anyone who decides on a wood or pellet boiler from ETA is choosing sustainability. This is not just in terms of fuel, but encompasses responsibility across the board, with sustainable workplaces in the region. More than 400 employees in Hofkirchen an der Trattnach have the best working conditions – including an in-house restaurant, bright assembly and storage halls, a fitness room and a sauna. There is even a free electric charging station for electric cars, which is supplied by the in-house photovoltaic system. This also covers all the power needed of a production hall and thus saves around 230 tonnes of CO₂ per year.

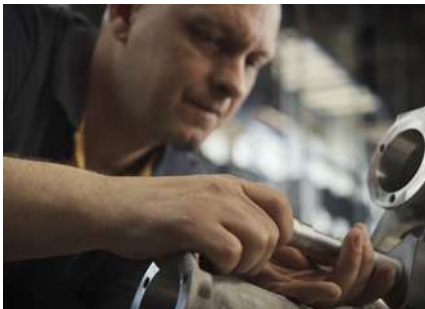

Pellet Boiler ETA ePE 7 to 13 kW

- 1** Pellets suction and return air connections DN50
 - 2** Drain for the safety valve, Union nut, flat sealing R1"
 - 3** Flow, union nut flat sealing R3/4"
 - 4** Return, union nut flat sealing R3/4"
 - 5** Air connection for operation with external air supply, NW80
 - 6** Flue gas connection \varnothing 113 and 130
- X = dimension variable depending on the connection line to the chimney

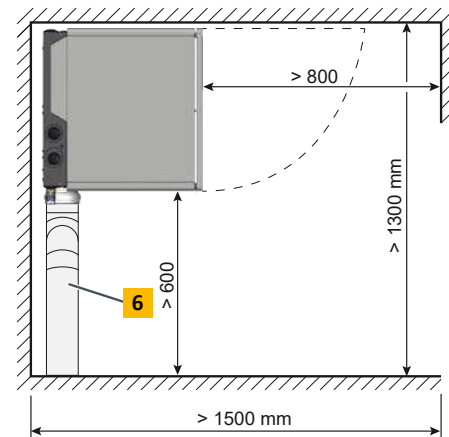
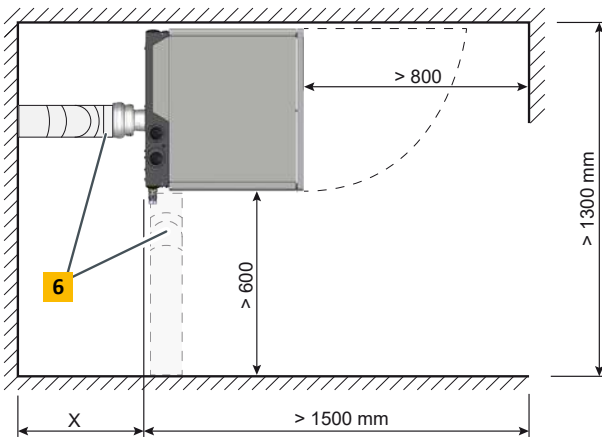
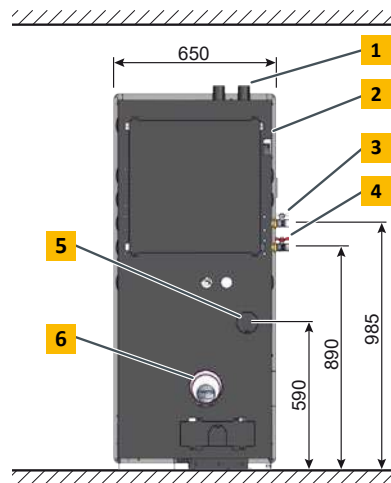
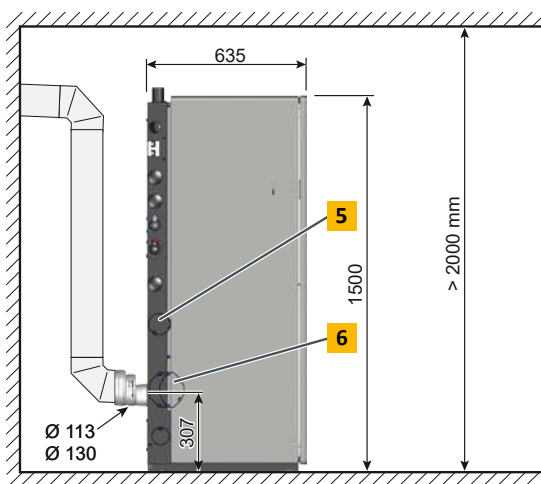



Pellet boiler ePE		7	9	11	13
Rated capacity	kW	2.2-7.2	2.7-9	3.2-10.8	3.8-12.6
Energy efficiency class**		A++			
Efficiency at partial/full load*	%	95.4 / 96.4	95.6 / 96	95.8 / 95.5	95.7 / 95.3
Transport dimensions, W x D x H	mm	660 x 635 x 1,530			
Weight	kg	258			
Water content	litres	37			
Free residual pump head of the integrated mixing circuit at $\Delta T = 20$ K for operation with a buffer or radiators	mWs / m ³ /h	7.8 / 0.31	7.6 / 0.39	7 / 0.47	6.4 / 0.54
Free residual pump head (at $\Delta T = 7$ K) for underfloor heating circuit operation	mWs / m ³ /h	4 / 0.89	3.8 / 1.11	3.5 / 1.33	3 / 1.55
Pellet bin on boiler (net)	kg	30			
Maximum distance to pellet store	m	20			
Ash box volume	litres	17.5			
Required flue draught	Pa	> 3 Pa A draught limiter is required above 25 Pa			
Electrical power consumption at partial/full load (=values with integrated precipitator)	W	24 / 39 (36 / 60)			
Electrical power consumption in ready mode	W	7			
Maximum permissible operating pressure	bar	3			
Temperature adjustment range	°C	55-90			
Boiler class		5 acc. to EN303-5:2018			
Suitable fuels		Pellets, ISO 17225-2-A1, ENplus A1			
Electrical connection		1 x 230 V / 50 Hz / 13 A			

*Data from the test report

**Association label (boiler + control system)

Technical changes and errors reserved!



conforms to
EU standards

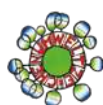

Austrian ecolabel

Pellet Boiler ETA ePE 15 to 20 kW

- 1** Pellets suction and return air connections DN50
- 2** Drain for the safety valve, Union nut, flat sealing R1"
- 3** Flow, union nut flat sealing R1"
- 4** Return, union nut flat sealing R1"

- 5** Air connection for operation with external air supply, NW80
- 6** Flue gas connection \varnothing 113 and 130

X = dimension variable depending on the connection line to the chimney

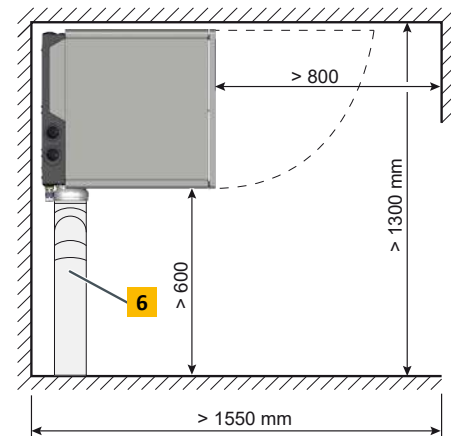
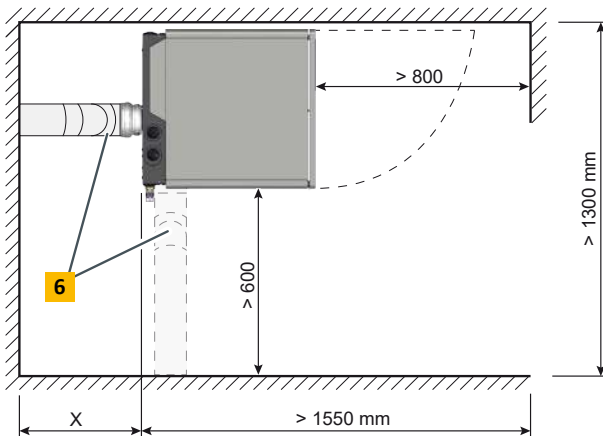
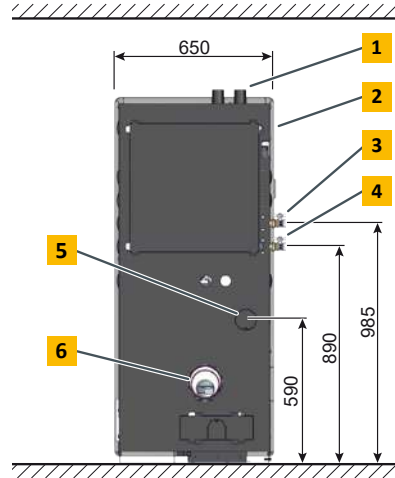
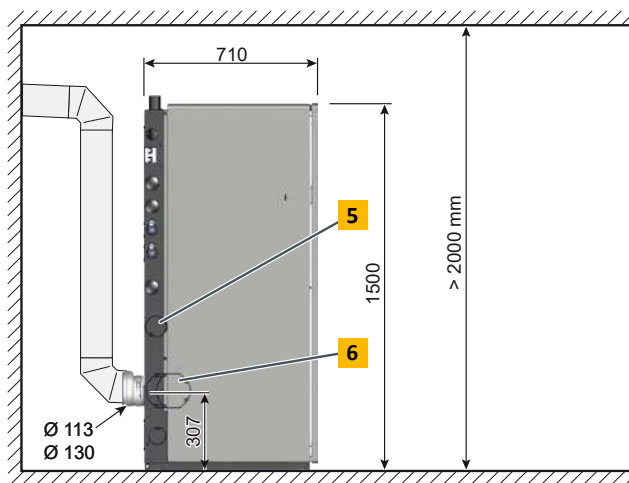



Pellet boiler ePE		15	18	20
Rated capacity	kW	4.5-14.9	5.4-18	6-20
Energy efficiency class**			A++	
Efficiency at partial/full load*	%	95.6 / 95	95.5 / 94.6	95.4 / 94.3
Transport dimensions, W x D x H	mm	660 x 707 x 1,530		
Weight	kg	293		
Water content	litres	42		
Free residual pump head of the integrated mixing circuit at $\Delta T = 20$ K for operation with a buffer or radiators	mWs / m ³ /h	6.1 / 0.64	5.1 / 0.78	4.5 / 0.86
Free residual pump head (at $\Delta T = 7$ K) for underfloor heating circuit operation With underfloor heating circuit operation, the maximum output is 13 kW.	mWs / m ³ /h	2.4 / 1.60		
Pellet bin on boiler (net)	kg	30		
Maximum distance to pellet store	m	20		
Ash box volume	litres	21		
Required flue draught	Pa	> 3 Pa A draught limiter is required above 25 Pa		
Electrical power consumption at partial/full load (=values with integrated precipitator)	W	24 / 41 (38 / 57)		
Electrical power consumption in standby*	W	7		
Maximum permissible operating pressure	bar	3		
Temperature adjustment range	°C	55 – 90		
Boiler class		5 acc. to EN303-5:2018		
Suitable fuels		Pellets, ISO 17225-2-A1, ENplus A1		
Electrical connection		1 x 230 V / 50 Hz / 13 A		

*Data from the test report

**Association label (boiler + control system)

Technical changes and errors reserved!



conforms to
EU standards

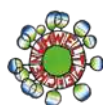

Austrian ecolabel

NOTES

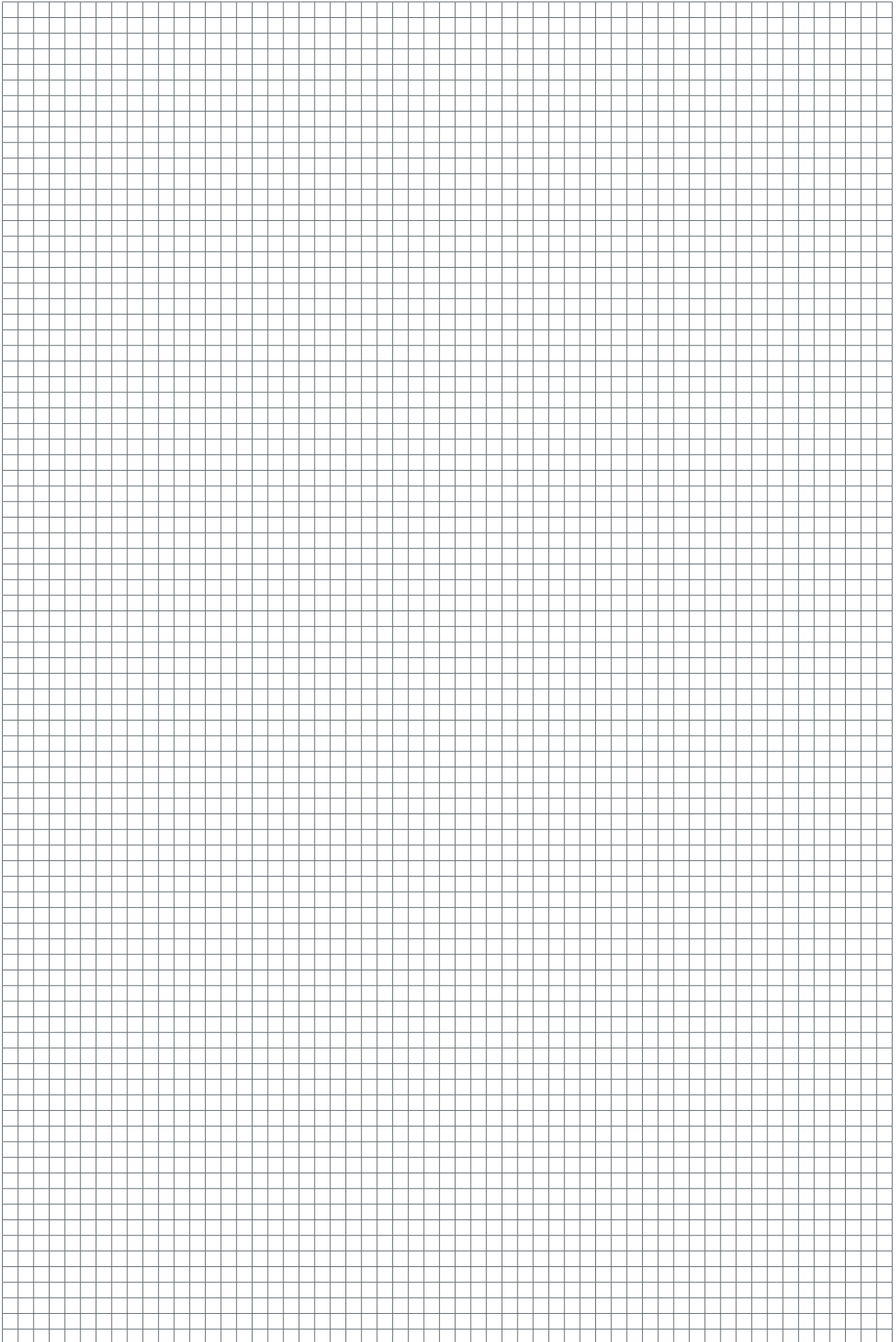

NOTES

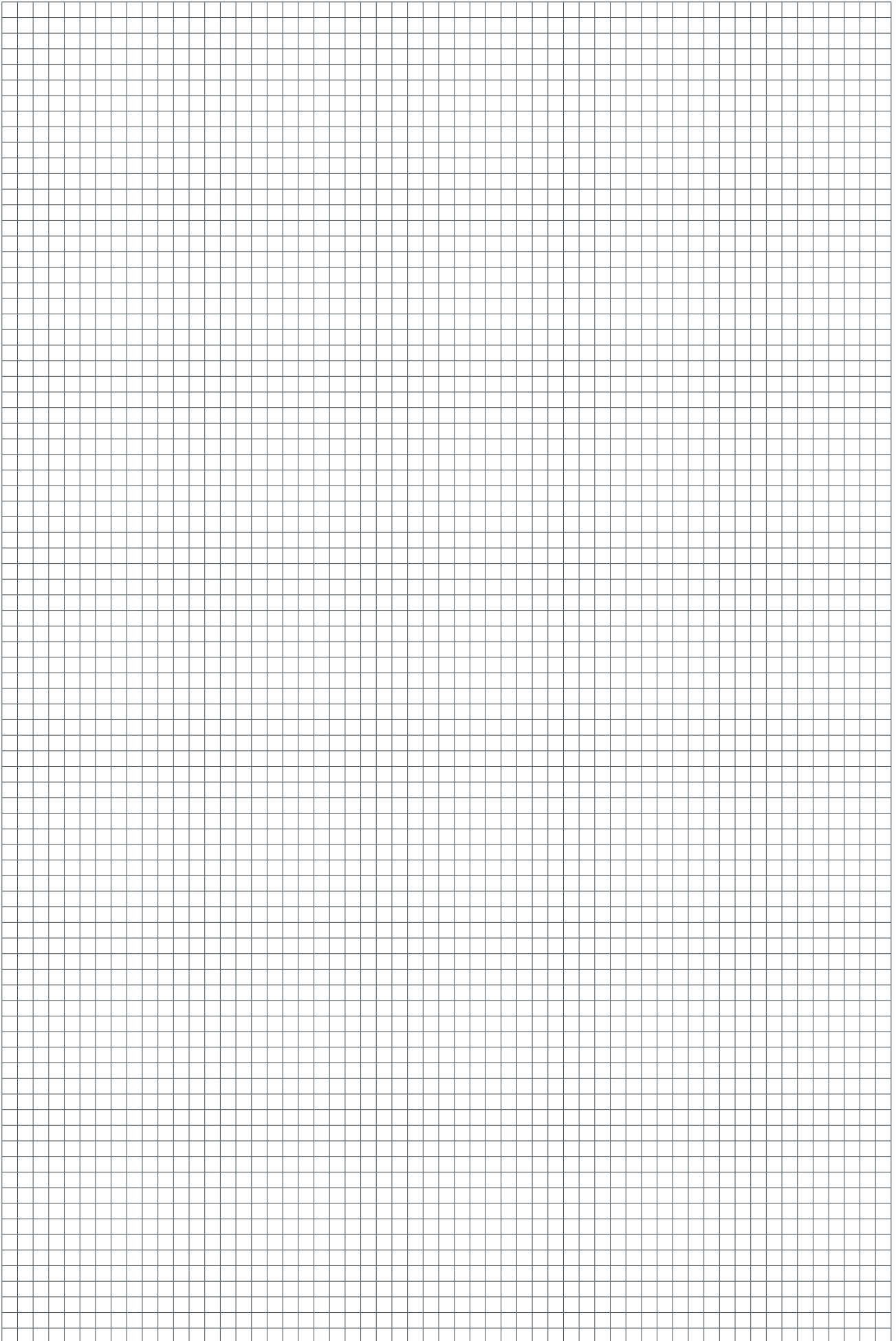



ETA Pelletboiler

ETA PU PelletsUnit	7 - 15 kW
ETA ePE pellet boiler	7 - 20 kW
ETA PC PelletsCompact	20 - 105 kW
ETA ePE-K pellet boiler	100 - 240 kW



ETA condensing heat technology

ETA ePE BW pellet boiler	8 - 22 kW
ETA BW condensing heat exchanger PU	7 - 15 kW
ETA BW condensing heat exchanger PC	20 - 105 kW



ETA SH log wood boiler and TWIN pellet boiler

ETA SH log wood boiler	20 - 60 kW
ETA SH-P log wood boiler	20 - 60 kW
with ETA TWIN pellet boiler	20 - 50 kW



ETA wood chip boiler

ETA eHACK wood chip boiler	20 - 240 kW
ETA HACK VR wood chip boiler	250 - 500 kW



ETA buffer tank

ETA buffer	500 l
ETA buffer tank SP	600 - 5.000 l
ETA buffer tank SPS	600 - 1.100 l

ETA hydraulic modules

- ETA fresh water module
- ETA stratified charging module
- ETA system separation module
- ETA mixing circuit module
- ETA heat transfer module and station

Your heating specialist will be happy to advise you:



ETA Heiztechnik GmbH
 Gewerbepark 1
 A-4716 Hofkirchen an der Trattnach
 Tel.: +43 7734 2288-0
 Fax: +43 7734 2288-22
 info@eta.co.at
 www.eta.co.at

Technical changes and mistakes reserved

In order to provide you the benefits of our continuous development, we reserve the right to change specifications without prior notice. Printing and typesetting errors or changes of any kind made in the interim are not cause for claims. Individual configurations depicted or described here are only available as options. In the event of discrepancies between individual documents regarding the scope of delivery, the information provided in our current price list shall prevail. Images and symbols may contain options that are available for an additional cost.

Photo source: ETA Heiztechnik GmbH, Lothar Prokop Photographie, istockphoto, Thinkstockphotos, Photocase, Shutterstock.
 94742-EN, Prospekt ETA ePE EN, 2022-11

